

RVC Status

Sketch of QCS Head Design

Kanazawa-san

Status as of 5.12.2014

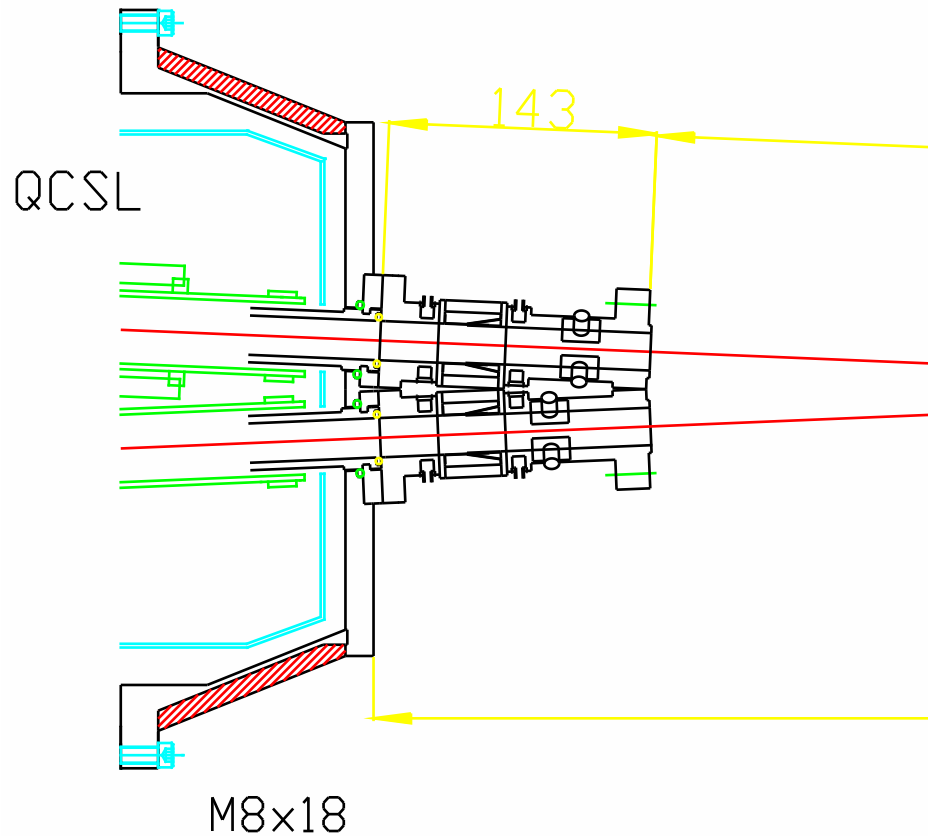

Sketch of QCS Head Design

Kanazawa-san

Status as of 5.12.2014

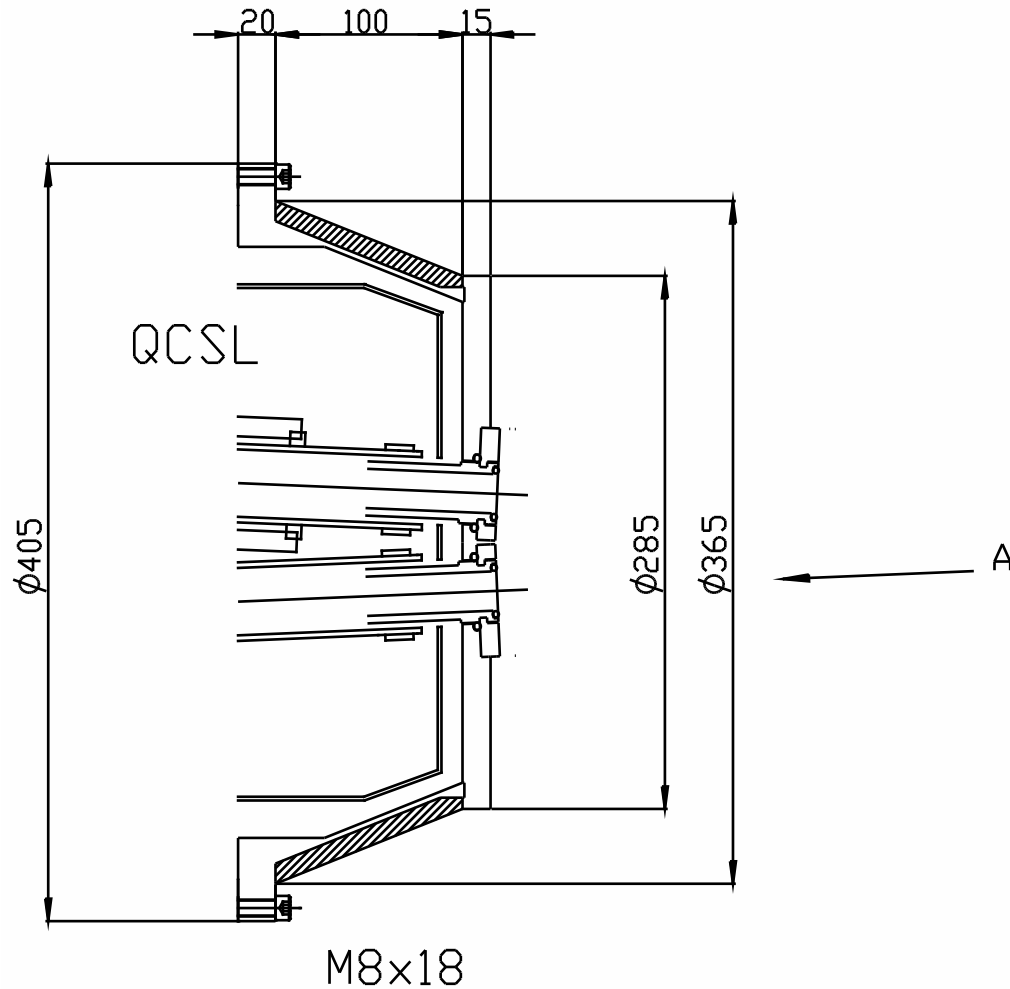

Sketch of QCS Head Design

Kanazawa-san

Status as of 5.12.2014

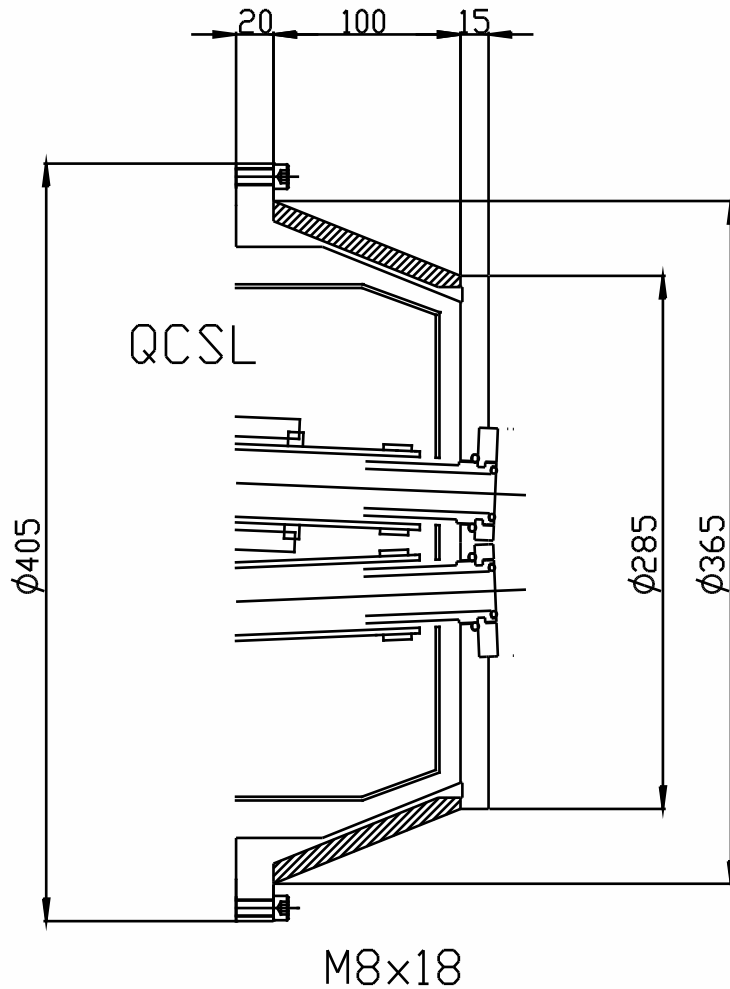

Status December 2013

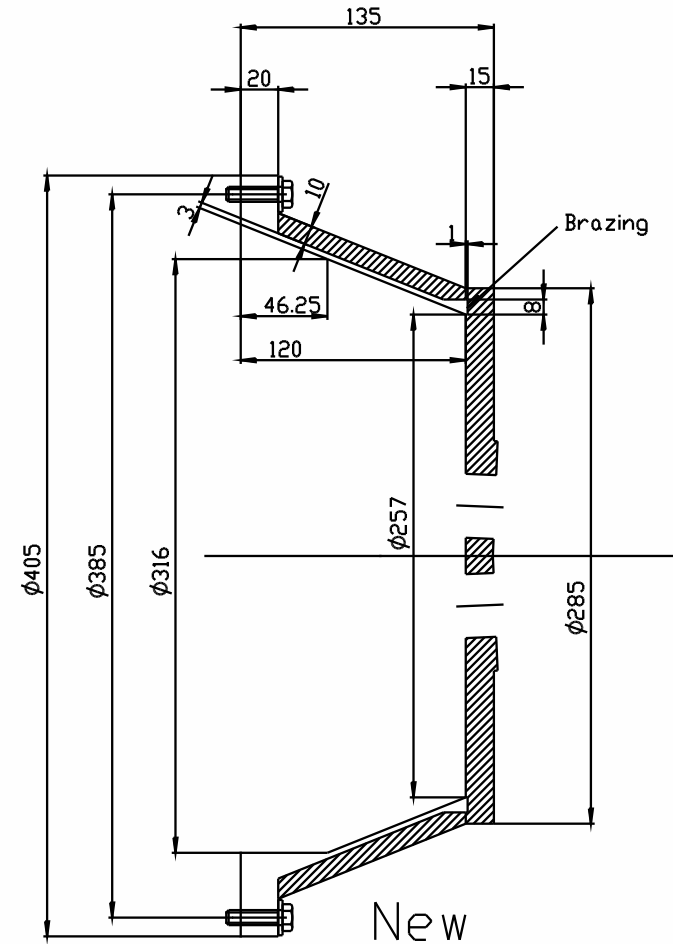

A

Sketch of QCS Head Design

Kanazawa-san

Status as of 5.12.2014

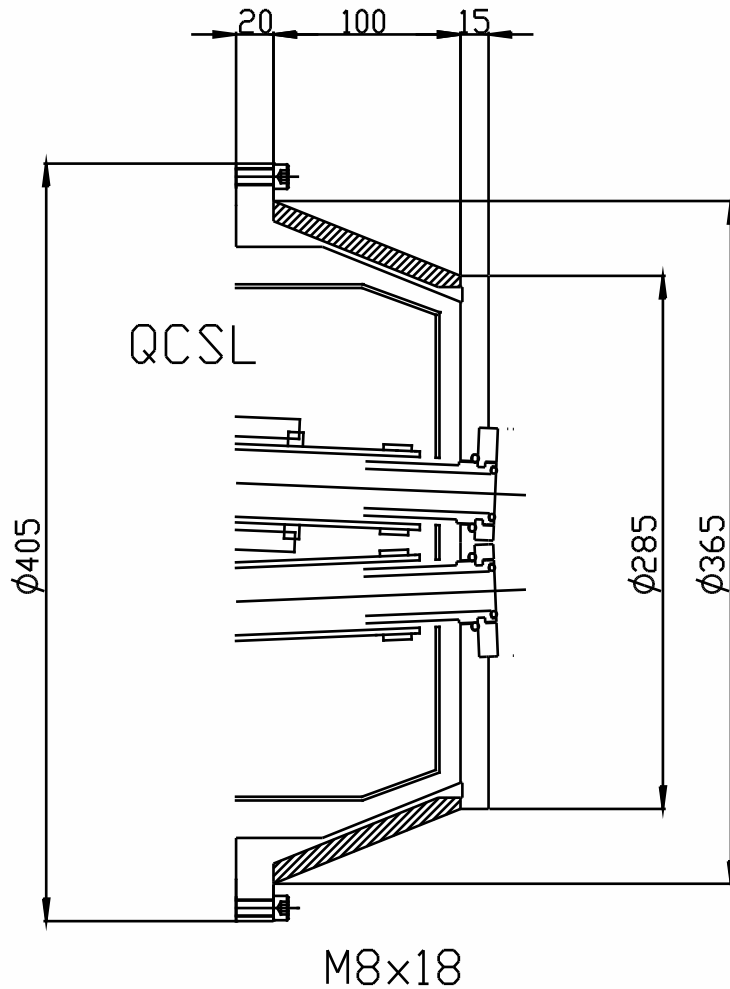

Status December 2013

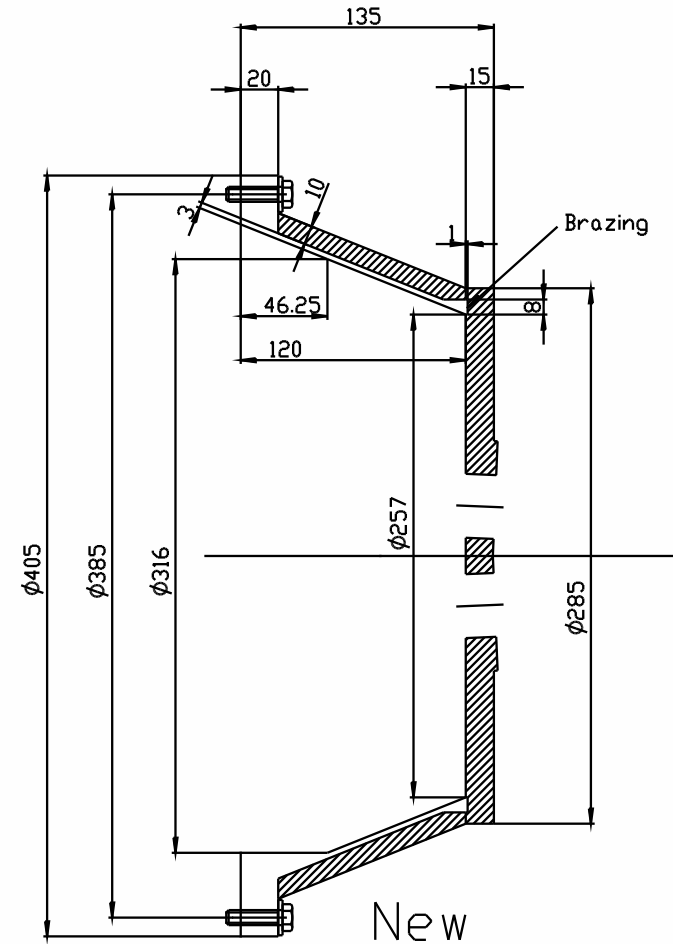

- No significant change since one year

Summary

- For Karsten to be able to proceed with the final RVC design he needs final and complete production drawings of QCS end flange and beam pipe

- Service space on QCS
 - space allocated in present RVC design will also be required for final design
 - location on circumference is adjustable