

PXD Slow Control

RC & PSC Testbeam Preparations

Thorsten Röder
roeder@mpp.mpg.de

Max-Planck-Institute for Physics

March 3, 2016



Control Architecture

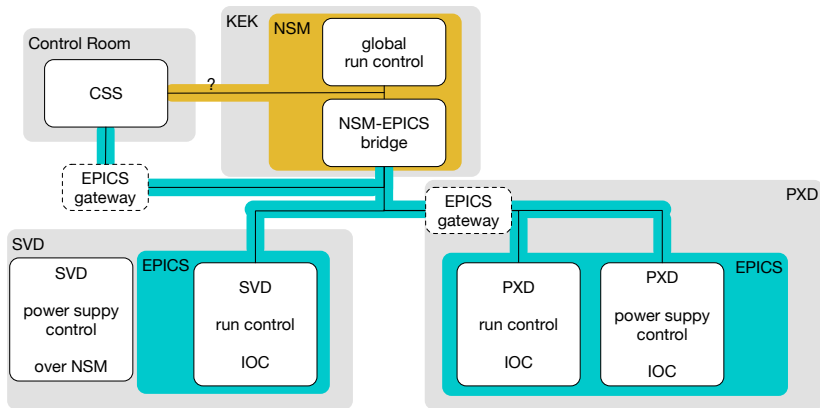

RC & PSC Statemachines

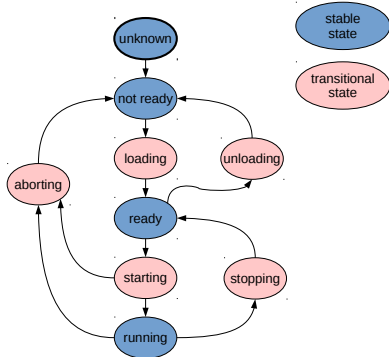

transitional states are not requested by the master.

handshake:

the next stable state is requested
the subdetector acknowledges by reporting the transitional state
when done, the subdetector reports the final state.

the requested state must be reachable from the current state via only one transitional state (i.e. request "running" from "not ready" is not allowed).

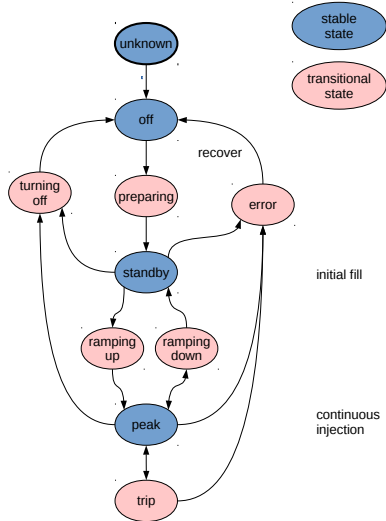

initial fill

continuous injection

Collecting error conditions

<https://belle2.cc.kek.jp/~twiki/bin/viewauth/Detector/SlowControl/RCPSCErrorConditions>

PXD Operation Matrix

Dummy Mode

| | OFF | STANDBY | PEAK |
|----------|--|--|---|
| NOTREADY | Frontend off DAQ off | ASICs+DHH ready DEPFETs not powered DAQ off | Frontend sending data DAQ off |
| READY | Frontend off DAQ links established | ASICs+DHH ready DEPFETs not powered DAQ links established | Frontend sending data DAQ links established |
| RUNNING | Frontend off DAQ processing triggers, ROIs. ONSEN sends dummy data | ASICs+DHH ready DEPFETs not powered DAQ processing triggers, ROIs. DHH sends dummy data | Frontend sending data. DAQ processing triggers, ROIs. |



Proposal for Local Control Options in GUI

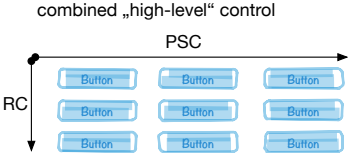

individual control

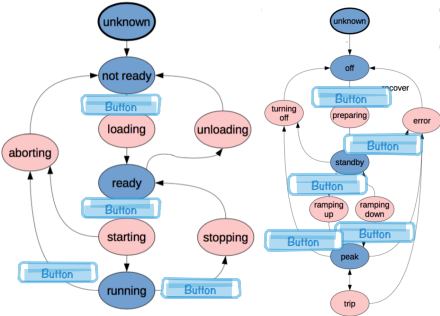

Master Mode: Decoupling Global and Local RC

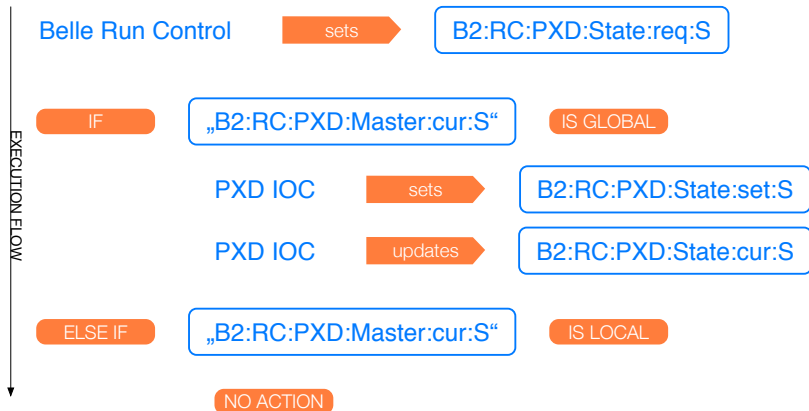

Proposal: Implementation using Code Snippets

```
state S_starting {
  entry {
    SET_PV(pv_state_current, State_STARTING);
    printf("new state reached: %d\n", pv_state_current);
    error = FALSE;
%%      #include "RC_starting_entry.st"
  }
  when(!error) {
    // do magic stuff at this stage
%%      #include "RC_starting_noerror.st"
  } state S_running
  when(error) {
    // do magic stuff at this stage
%%      #include "RC_starting_error.st"
  } state S_aborting
}

state S_running {
  entry {
    SET_PV(pv_state_current, State_RUNNING);
    printf("new state reached: %d\n", pv_state_current);
    error = FALSE;
%%      #include "RC_running_entry.st"
  }
  when(pv_state_requested == State_READY) {
%%      #include "RC_running_ready.st"
  } state S_stopping
  when(pv_state_requested == State_NOT_READY) {
%%      #include "RC_running_notready.st"
  } state S_aborting
}
```



PXD Slow Control

RC & PSC Testbeam Preparations

Thorsten Röder
roeder@mpp.mpg.de

Max-Planck-Institute for Physics

March 3, 2016

