

# Commissioning and installation of the new small-diameter Monitored Drift Tube detectors for the phase-1 upgrade of the ATLAS muon spectrometer

Elena VOEVODINA

*on behalf of MPI SMDT group*



Max-Planck-Institut für Physik  
(Werner-Heisenberg-Institut)

*DPG-Frühjahrstagungen  
March 15<sup>th</sup>-19<sup>th</sup>, 2021*



MAX-PLANCK-GESELLSCHAFT

## *Introduction*

- ***ATLAS Muon Spectrometer Phase-1 Upgrade***
- ***New BIS78 sMDT Detector for the ATLAS Muon System***
- ***Overview of the Surface Commissioning Protocol***

## *BIS78 sMDT surface commissioning @CERN*

- ***Gas Leak Test***
- ***Connectivity and Noise Rate Test***
- ***Cosmic-Ray Test***

## *BIS78 sMDT and RPC detectors integration*

- ***Integration Procedure***
- ***Interference Noise Test***
- ***Final Mechanics & Services Installation***

## *Installation & commissioning @ATLAS Cavern*

- ***Sector Preparation***
- ***Installation***
- ***Commissioning***

# *Introduction*

## Barrel muon trigger upgrade at $|\eta| < 1.3$ :

The *Barrel Inner (BI) Upgrade* project consists of:

- **new triple-Resistive Plate Chamber (t-RPC)** -> **276** detectors for the triggering:
  - to close acceptance gaps by compensating the potential efficiency loss of the present RPC
  - to improve the trigger selectivity
  - to increase the redundancy of the muon system
- **new small Monitored Drift Tubes chambers (sMDT)** -> **96** detectors for the tracking:
  - to replace current MDT chambers and allow for a 3-station RPC trigger
  - to increase the tracking rate capability

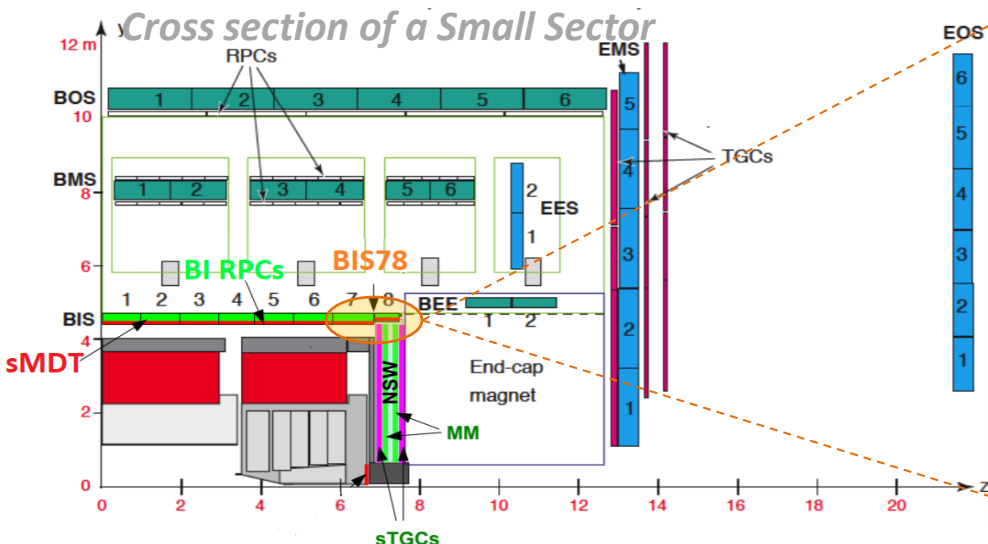

In 2019/21 (Long shutdown-2) the BIS78 Phase-1 Upgrade project will realize as a pilot for Phase-2:

16 sMDT and 16 t-RPC chambers will install in the barrel-endcap transition region at  $1.0 < |\eta| < 1.3$

*In total: ~ 11000 drift tubes!*



# BIS78 sMDT Detector for ATLAS Muon Spectrometer Phase-I Upgrade

*BIS78 project in Phase-1/Run-3 March 2022*

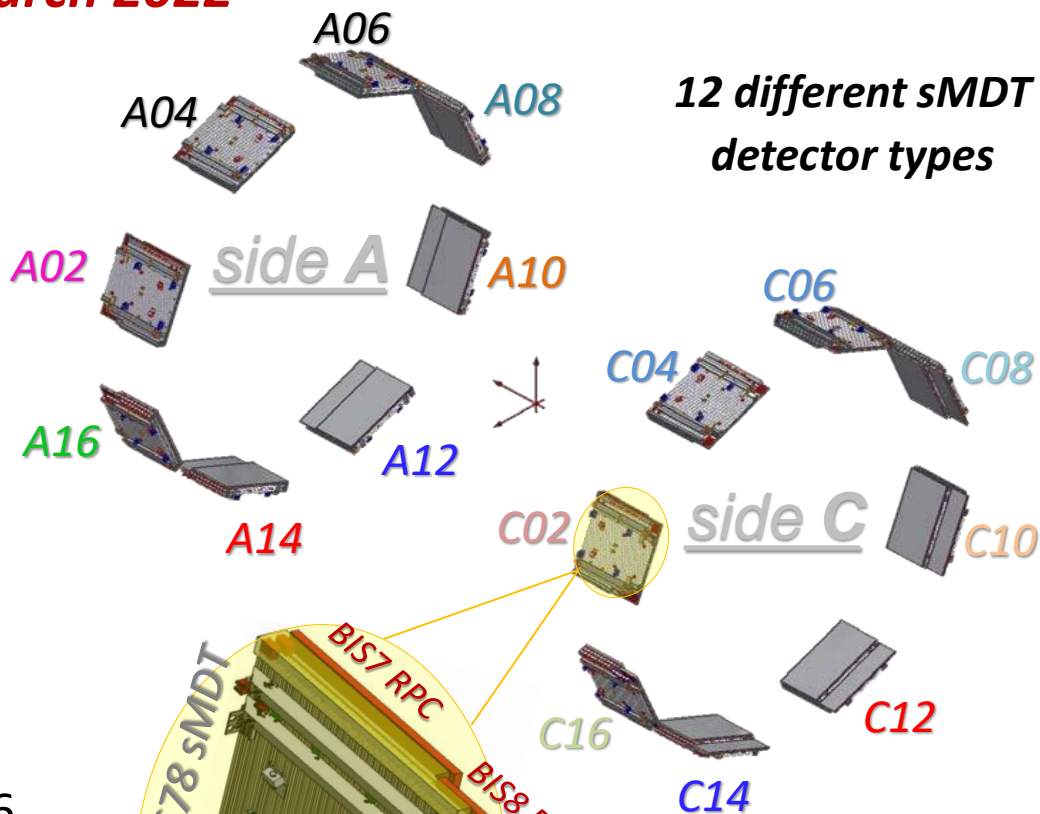
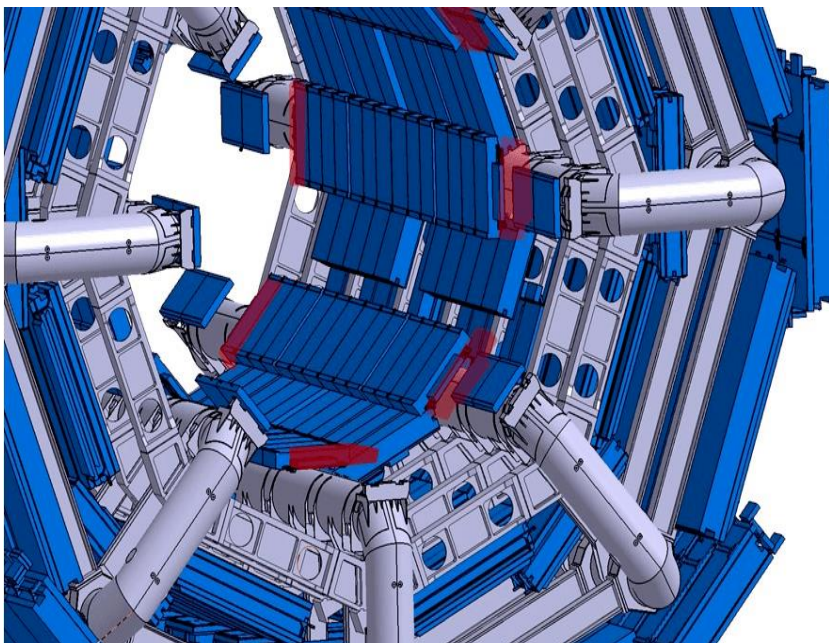

## Layout:

16 new muon stations replacing the 16 existing BIS7-8 MDTs. Each station made of:

- one BIS78 sMDT detector
- two t-RPC triplets: BIS7 RPC + BIS8 RPC

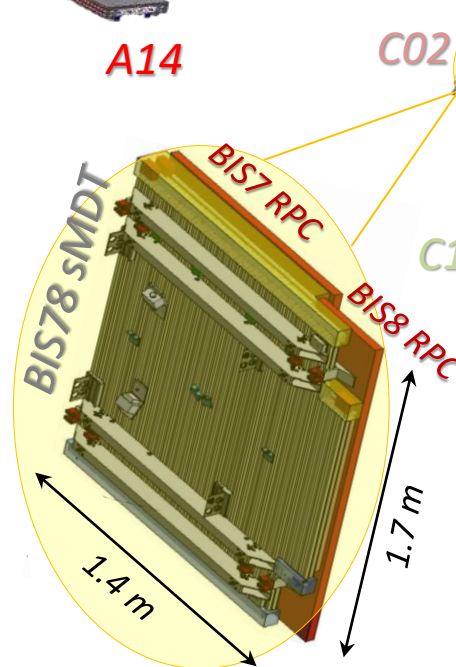

# New small Drift Tube Chamber Technology

The **sMDT Technology** has been developed since 2008 in order to cope with the expected high background rates at the HL-LHC

*sMDT baseline parameters*

Properties	Current MDT	New sMDT
Tube Diameter	30 mm	15 mm
Number of tube layers	4	8
Operating Gas Mixture	Ar: CO <sub>2</sub> (93:7)	Ar: CO <sub>2</sub> (93:7)
Operating Pressure	3 bar	3 bar
Operating HV working point	3070 V	2730 V
Gas gain	$2 \times 10^4$	$2 \times 10^4$
Max. Drift time	$\sim 720$ ns	$\sim 175$ ns
Single tube space resolution	$83 \pm 2$ $\mu$ m	$106 \pm 2$ $\mu$ m

MDT  
Ø 30 mm

new sMDT  
Ø 15 mm



50% occupancy

6.5% occupancy

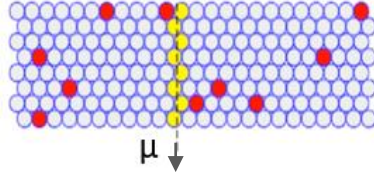
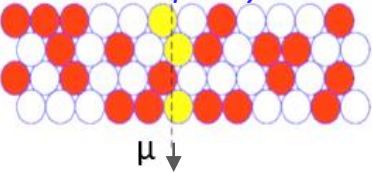

**Drift Time Spectrum**

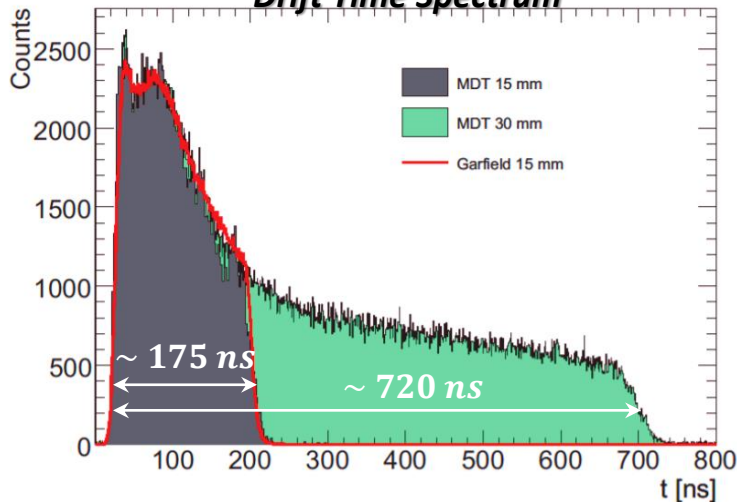

## Main Advantages of the 15 mm Ø sMDT detector:

- ✓ 10 times high rate capability with respect to the current MDT detectors, i.e. 8 times lower background detector occupancy
- ✓ 4 times lower electronics dead time (= max. drift time)
- ✓ 2 times more tube layers within the same detector volume allowing for additional increase in the muon tracking efficiency
- ✓ No aging effects after foreseen integrated luminosity of HL-LHC (even up to 9 C/cm)

See more info in M. Rendel's talk: Construction of new small-diameter Monitored Drift Tube (sMDT) chambers for the HL-LHC upgrade of the ATLAS muon spectrometer

# sMDT + RPC BIS78 Validation Tests Protocol @CERN

## sMDT QA/QC

- ❖ Visual Inspection
- ❖ Preparation phase for QC
- ❖ Leak Rate Test
- ❖ Connectivity & Noise Rate Test
- ❖ Cosmic Ray Test

## RPC BIS78 QA/QC

- ❖ Visual Inspection
- ❖ Detector Components Validation:
  - > Gas gap tightness
  - > V/A characteristic
  - > Gap conditioning & stability tests @GIF++
  - > FE Board Test, etc ...
- ❖ Singlet/Triplet Assembly
- ❖ Singlet/Triplet Cosmic Ray test

## sMDT + RPC BIS78 Integration

- ❖ Final Mechanics & Services Installation
- ❖ Connectivity & Interference Noise Test
- ❖ Final Certification Tests

## Final BIS78 Detector Module Installation @P1

# ***BIS78 sMDT surface commissioning @CERN BB5***



# 16 BIS78 sMDT @CERN BB5 facility

- ✓ 8 “A-side” sMDT detectors have been shipped from MPI-Munich to CERN in 2019 year
- ✓ 8 “C-side” sMDT modules have been delivered from the MPI-Munich in 2020 when the storage and test spaces at CERN were available

*Assembled sMDT detectors arrived from MPI (Munich) to BB5 facility (CERN, Geneva)*



*Short-term sMDT storage @CERN BB5*

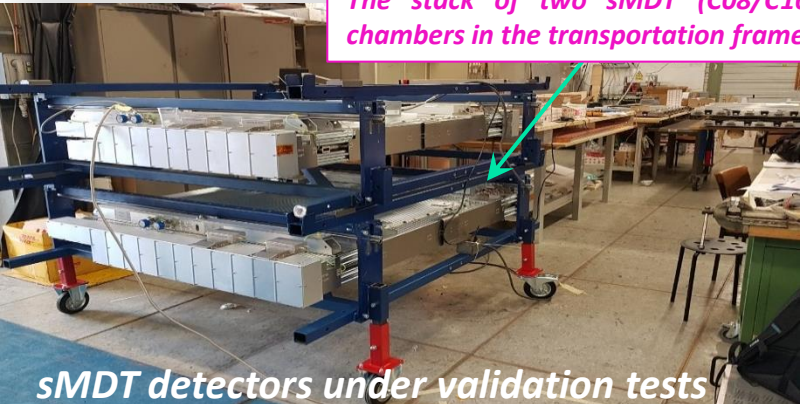

*sMDT detectors under validation tests*

# Gas Leak Rate Measurement

## Determination of Gas Leak for each Multilayer (ML)

- Detector is pressurized at **3 bar** in the operating gas mixture **Ar: CO<sub>2</sub> (93: 7)**
- Pressure measurement  **$p(t)$**  -> Baratron pressure gauge
- Temperature measurement  **$T(t)$**  -> 12 on-chamber sensors
- Duration: **> 24 hours**

sMDT A02 is under Gas Leak Test

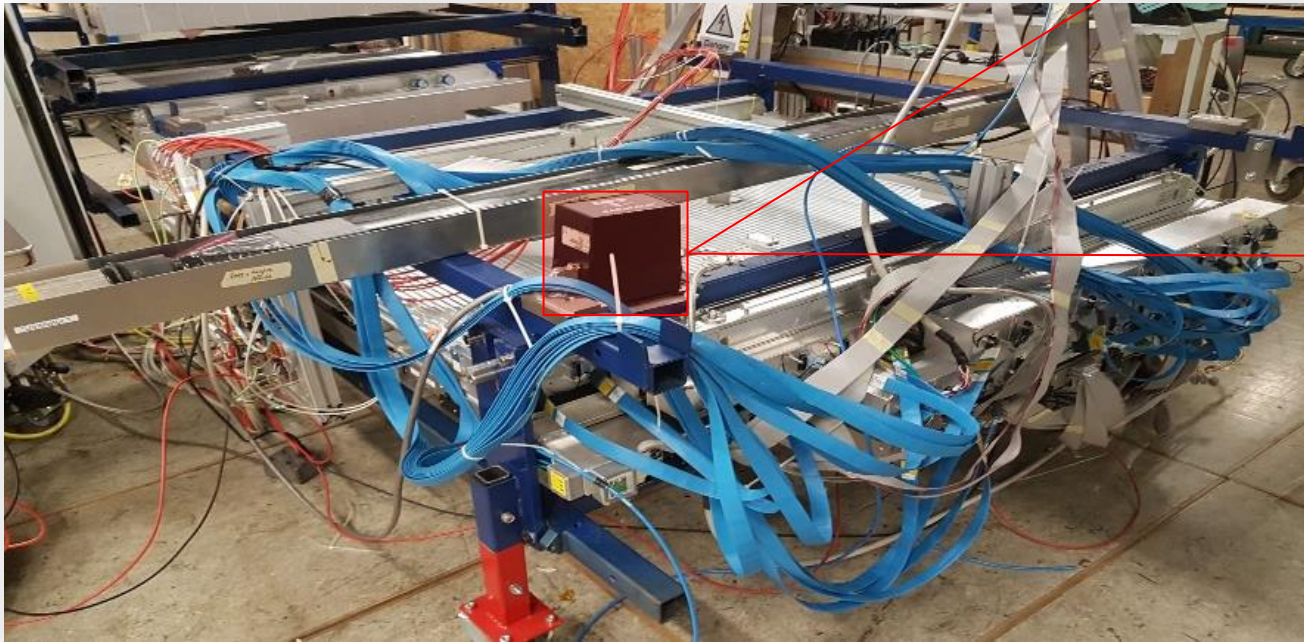

MKS Instruments  
390HA-00001SP12



Accuracy:  
0.3 mbar at 3000 mbar

✓ All 16 sMDT chambers fulfilled the stringent leak rate limit!

*\*All data and results obtained at BB5 facility are verified against measurements in MPI!*



# Connectivity & Electronics Noise Test

Measurement of the accidental hit rate in each tube with and without high voltage

sMDT setup @CERN BB5:  $WP = 2730V, P = 3 \text{ bar}$  in Ar:CO<sub>2</sub> (93:7)



Movable service rack

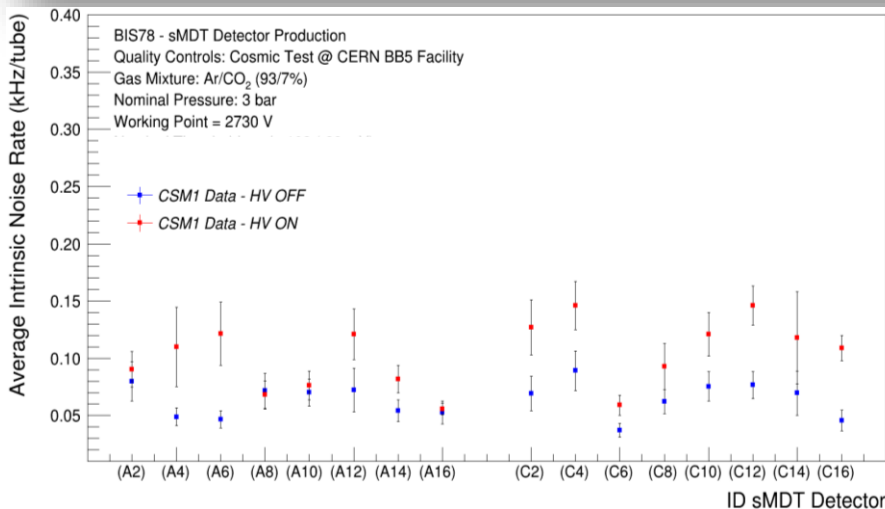

## Noise Rate Test Summary:

→ "A/C-side" sMDT chambers

Noise Rate (HV OFF) =  $(63.5 \pm 6.2) \text{ Hz/tube}$

Noise Rate (HV ON) =  $(102.8 \pm 9.7) \text{ Hz/tube}$

Number of disconnected/dead tubes: 20



# Cosmic Ray Test

Cosmic-ray run to acquire a dataset corresponding to ~1 million cosmic muons through the chamber

**sMDT setup @CERN BB5: WP = 2730V, P = 3 bar in Ar:CO<sub>2</sub> (93:7)**

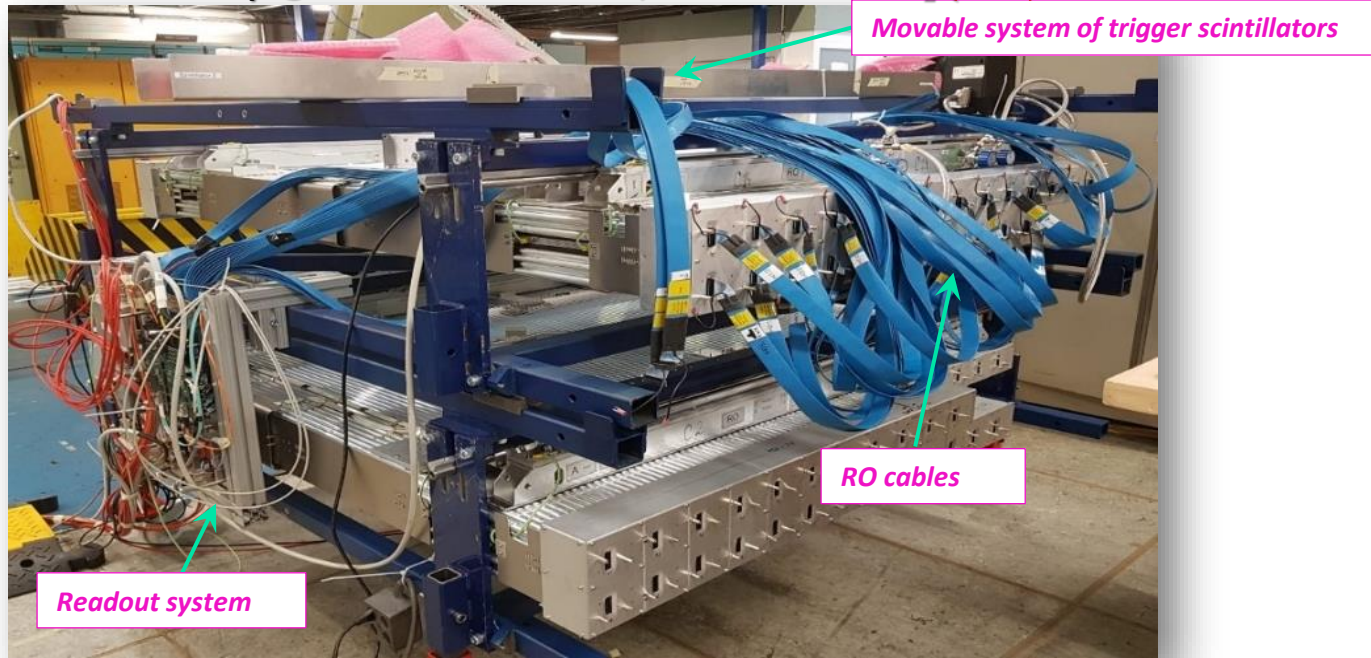

✓ **Measurement of the maximum drift-time** → average sMDT max. drift time is  $(194.84 \pm 1.05)\text{ns}$   
*At the same operational parameters, maximum drift time for every tube in a chamber should be the same.*

✓ **Measurement of the single tube resolution** → average sMDT spacial resolution is  $(141.7 \pm 6.2)\mu\text{m}$   
*which is in agreement with the expectation from the test beam measurement with high energy muons.*

✓ **Meas. muon detection efficiency of each tube** → average efficiency is  $(97.4 \pm 0.3)\%$   
*within the ATLAS requirements*

**The muon efficiency is < 100% because of the efficiency drop close to the tube wall!**

# 16 BIS78 sMDT status @CERN

Typical validation test rate: 1 fully validated chamber per 3 days!

ID Chamber	Visual Inspection	Gas Leak Rate Test	Connectivity & Electronic Noise Test	Cosmic Ray Test
A02	Validated	Validated	Validated	Validated
A04	Validated	Validated	Validated	Validated
A06	Validated	Validated	Validated	Validated
A08	Validated	Validated	Validated	Validated
A10	Validated	Validated	Validated	Validated
A12	Validated	Validated	Validated	Validated
A14	Validated	Validated	Validated	Validated
A16	Validated	Validated	Validated	Validated
C02	Validated	Validated	Validated	Validated
C04	Validated	Validated	Validated	Validated
C06	Validated	Validated	Validated	Validated
C08	Validated	Validated	Validated	Validated
C10	Validated	Validated	Validated	Validated
C12	Validated	Validated	Validated	Validated
C14	Validated	Validated	Validated	Validated
C16	Validated	Validated	Validated	Validated

**COMPLETED!**

sMDT "C-side" Storage @Meyrin bldg. 175



Successful and on-time commissioning of the BIS78 A/C-side sMDT detectors have been fully completed @CERN BB5 facility.



7 tested detectors have been safety stored @CERN Meyrin site (bldg. 175)



1 (C06) chamber has been stored at the BB5 facility for the mechanics improvement activity

**"C-side" chambers will be re-validated again before the final installation!**

# *BIS78 sMDT and RPC Integration*



# sMDT + RPC Integration

The integrated mechanical design of the two chambers with low tolerances are required.



The mechanical adjustment accuracy is about 0.5 mm, fulfilling the requirements on the chamber alignment in the detector.

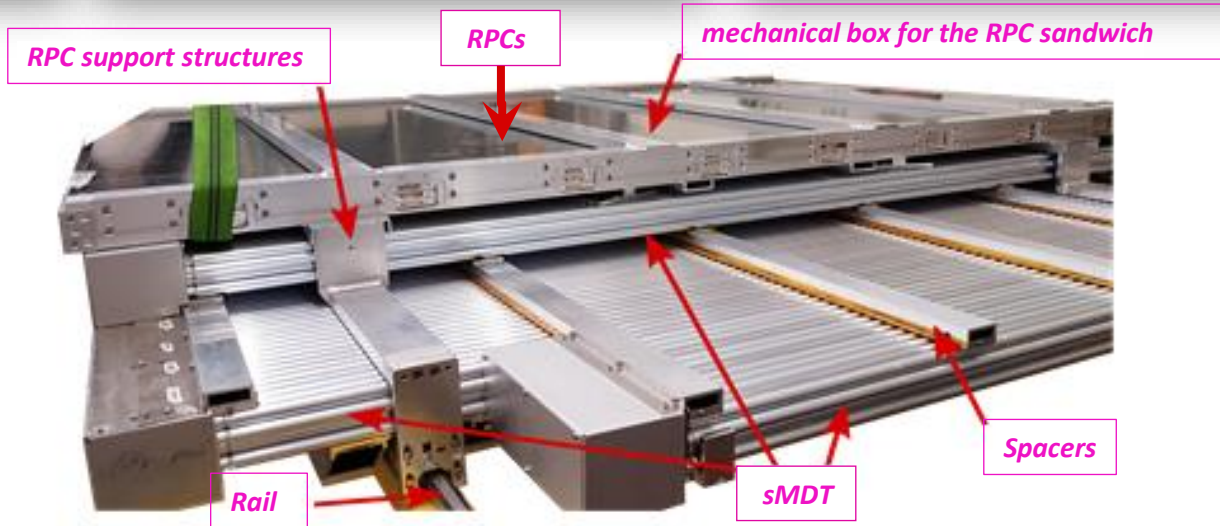

✓ 8 “A-side” sMDT chambers have been successfully integrated with RPCs!

# BIS78 sMDT Interference Test

BIS78 A04 - Interference Study @BB5

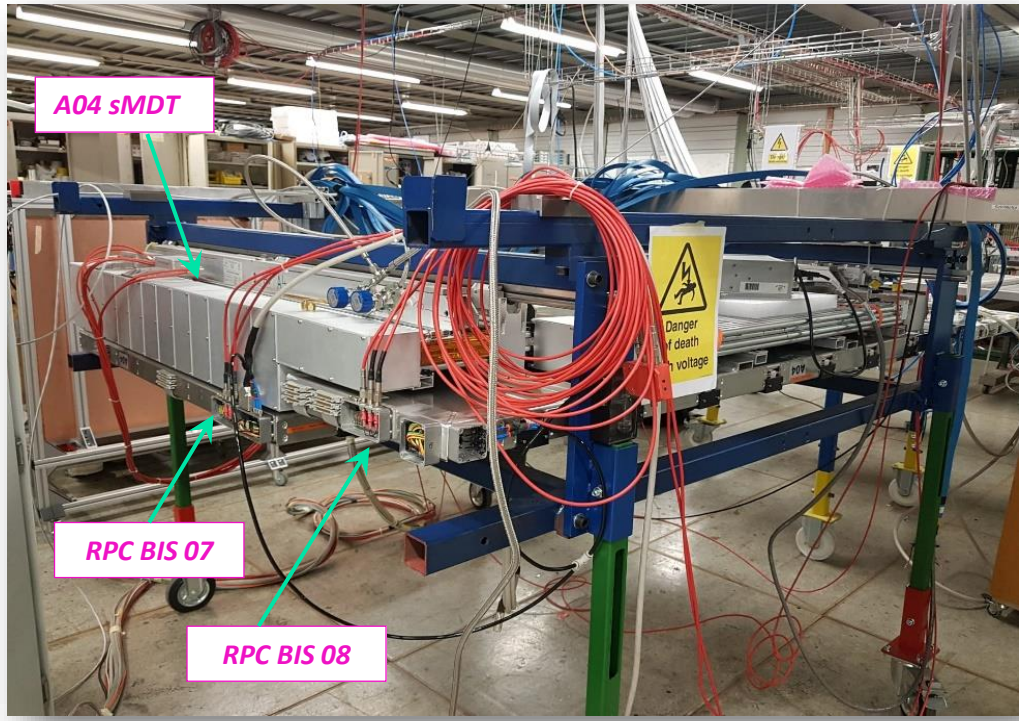

BIS78 A04 - Interference Test Result

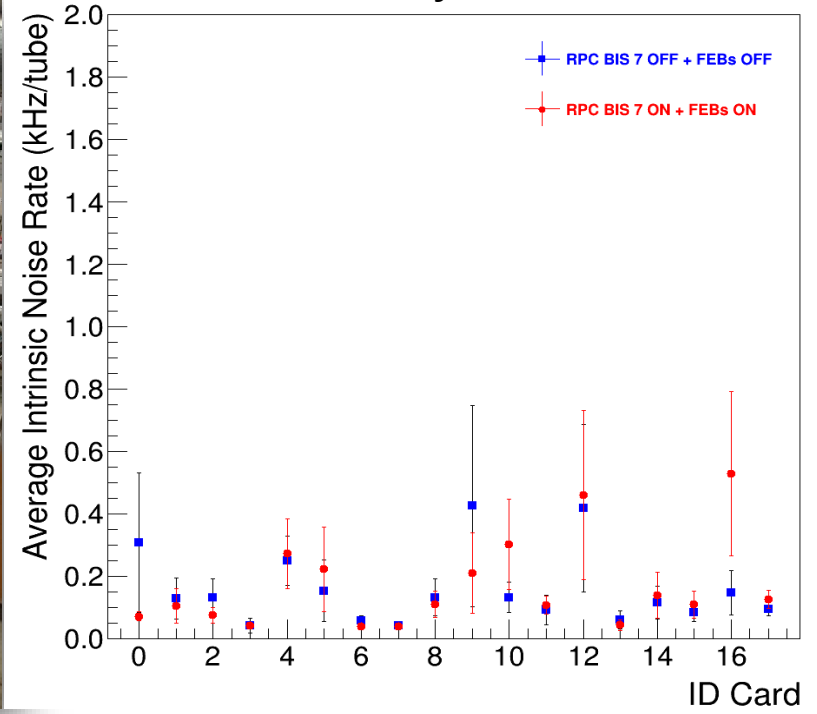

→ average noise rate for sMDT A04 with RPC system OFF is  $(0.43 \pm 0.03)$  kHz/tube

→ average noise rate for sMDT A04 with RPC system ON is  $(0.17 \pm 0.03)$  kHz/tube

Detailed study shown that the effect of the RPC detector + its electronics is negligible to sMDT system (chamber + its electronics @ operating THR. = -39 V) in the term of noise!

✓ All 8 “A-side” sMDT chambers have been passed test!



Each BIS78 sMDT detector must be equipped 4 B-field, 4 Axial - Praxial and 2 CCC sensors

The B-field sensors and chamber-to-chamber alignment systems of the MDT chamber are re-used for the new sMDT system again

A04 sMDT Final Services Installation @BB5

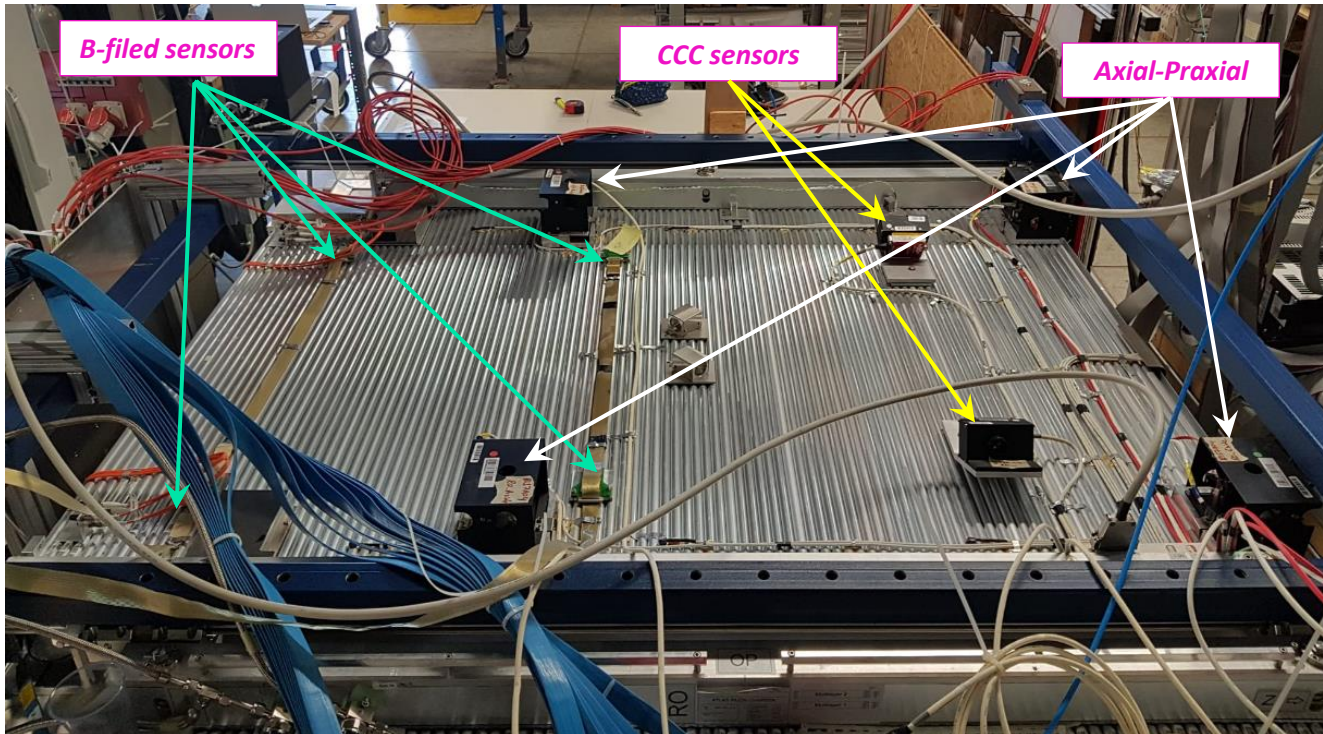

Cables installation & routing



B-sensor preparation



# *Installation & commissioning @ATLAS Cavern*



## BIS7A /BIS8A MDT chambers decommissioning

- Disconnection:
  - Gas line
  - Mezzanine, HV, B-/T-sensors, grounding & alignment cables
- Dismounting

*MDT chamber deinstallation*

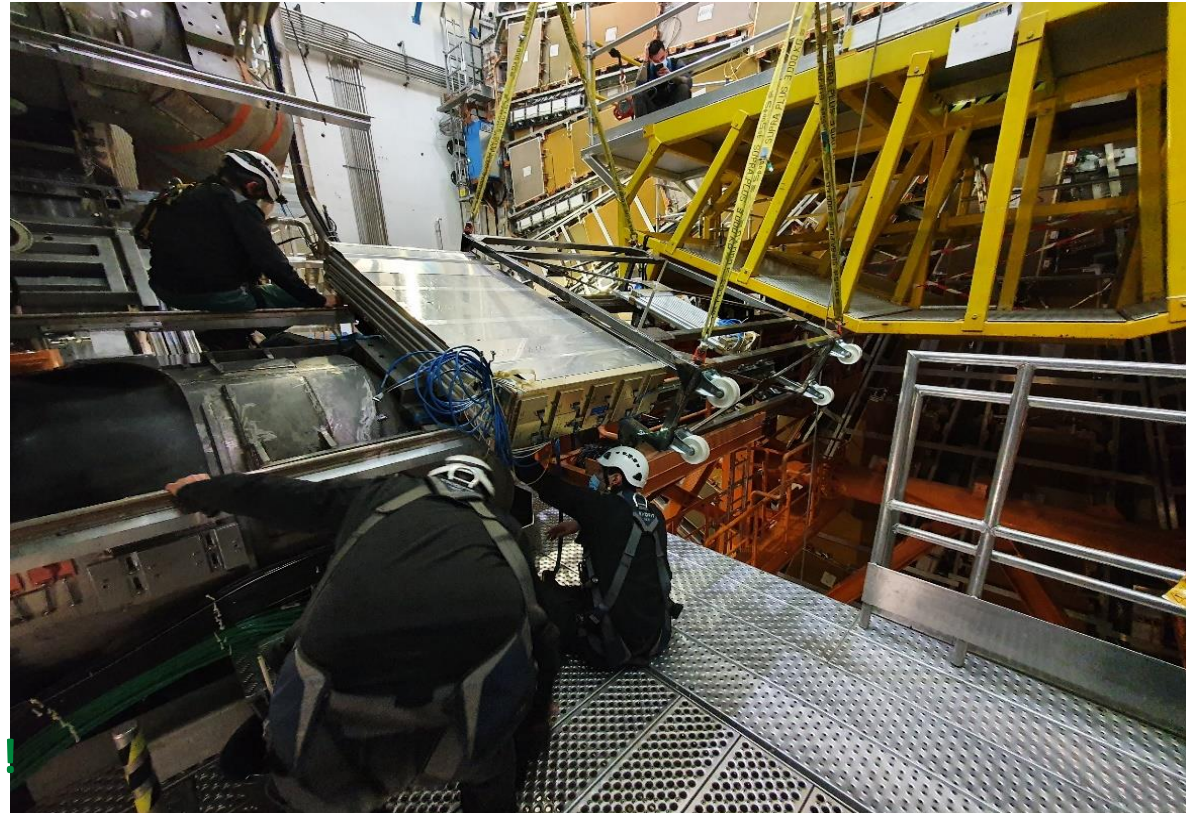

All activities in the ATLAS Cavern have been agreed upon with the Technical coordination team.

✓ Old "A-side" MDT subsystem have been removed from ATLAS!



17<sup>th</sup> of September 2020 the first BIS78 Detector Module has been successfully installed to the A04 sector of the ATLAS Muon spectrometer.

## Installation Sequence:

- Insertion into the installation frame
- Lowering into the ATLAS Cavern, change of cranes
- Docking of the installation frame to the ATLAS Muon Spectrometer rail system
- Installation of the muon station with two winches
- Final positioning and fixation of support frame on rails

### *Insertion into the frame*

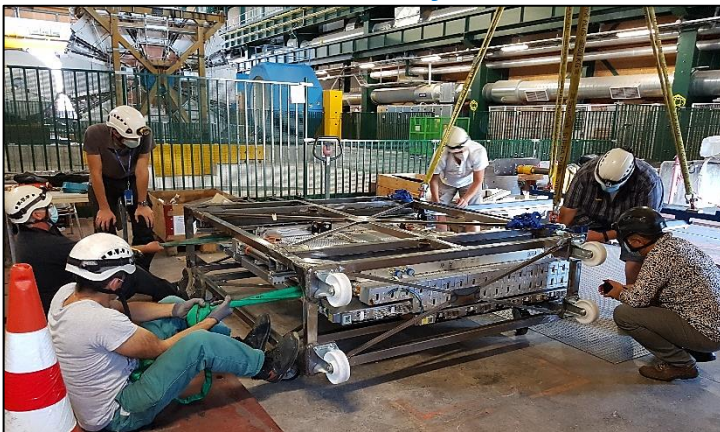

### *Lowering*

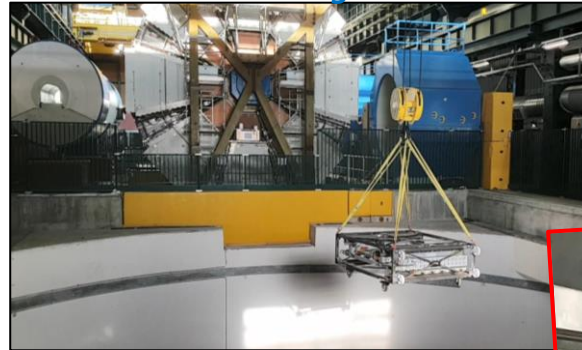

### *Docking*

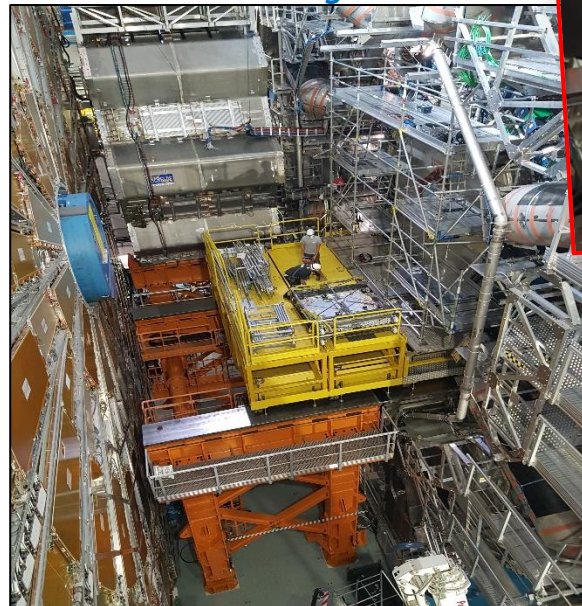

### *Installation*

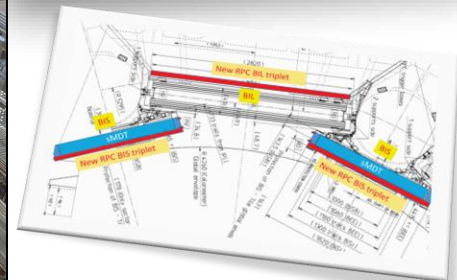



*Insertion into the installation frame*



*Lowering into the ATLAS Cavern*



*Docking to the ATLAS Muon System rail system*

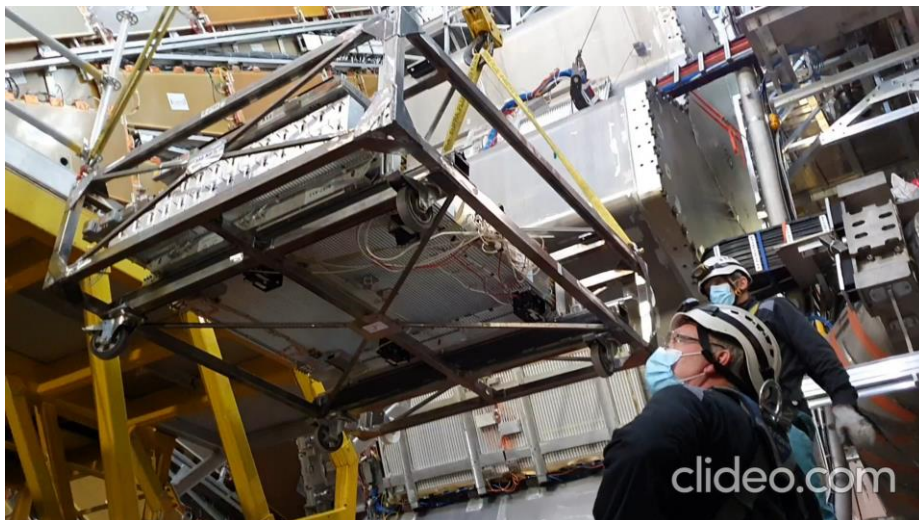

*Installation of the station with two winches*

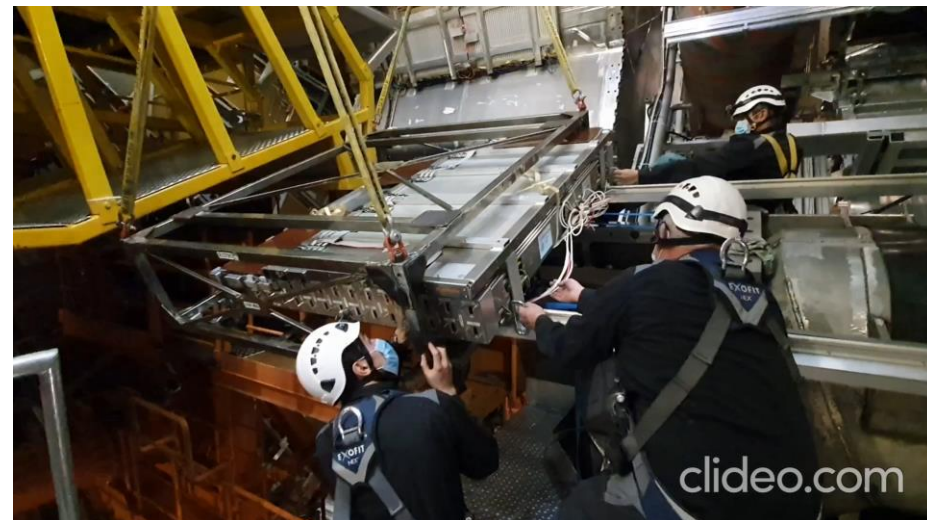



# BIS78 sMDT Detector Commissioning

The new sMDT subsystem has been successfully implemented/integrated in the ATLAS operational system.

## Monitored Drift Tubes

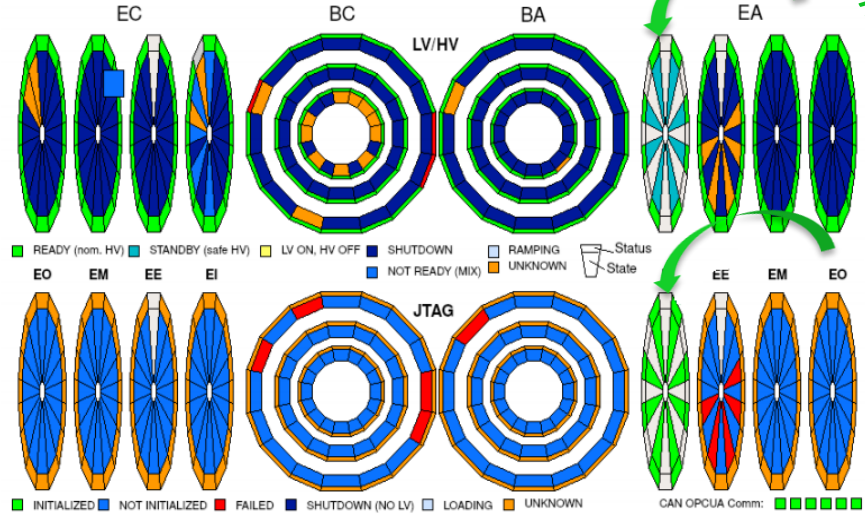

All sMDT BIS7A Det. under HV 2730V

Mezzanines and CSMS on 8 sector configured

- ✓ Alignment connected and checked -> chamber in expected positions;
- ✓ Gas line connected, flushed and @3 bar;
- ✓ 2 of each CSMS, CSMS-motherboards and MDMs installed and checked;
- ✓ Service cables (mezzanine, HV, B-/T-sensors and grounding) connected;
- ✓ LV and fibers checked to ensure right mapping;
- ✓ B-/T-sensor and front-ends V-/T-sensor readout checked;
- ✓ LV and HV applied and all currents in expected range.

Infrastructure		
GAS SYSTEM	READY	OK
GAS MONITORING	READY	OK
RACKS	READY	E
48V GENERATORS	READY	OK
CAEN SYSTEM	NOT_READY	E
MROD CRATES	READY	OK
TTC CRATES	READY	OK
EALIGN CRATES	SHUTDOWN	E
ELMB POWER	READY	OK
HV STDBY CTRL	OPERATIONAL	OK
FE ELTX MON	READY	W
BARREL ALIGN	READY	OK
ENDCAP ALIGN	NOT_READY	U
BEAM INTERLOCK	READY	OK
CAEN RESET NET	READY	OK
MDT DCS SYSTEMS	READY	W
MUON COOLING	NOT_READY	E

Run Status/DAQ/DDC		
Run:	388324	Evs: 506.21 M
Type:	Noise	Dropped: 0
State:	RUNNING	Mezz: 0
LB:	1502	
Run:	385658	Evs: 0
Type:	Noise	Dropped: 0
State:	UNKNOWN	Mezz: 0
LB:	3	
Run:	387921	Evs: 0
Type:	Noise	Dropped: 0
State:	UNKNOWN	Mezz: 0
LB:	0	
Run:	388324	Evs: 506.21 M
Type:	Noise	Dropped: 0
State:	RUNNING	Mezz: 0
LB:	1502	

LHC: MDT Beam Injection Permit			
Beam Mode	NO BEAM		
Inj. Permit MDT	FALSE	Muon	FALSE
Stable Beams Signal	FALSE	BeamSafe	FALSE
HV StandBy Ctrl	VO_UNSTABLE		

Magnets	
Toroid	0 A Solenoid 0 A
Configuration	
Current MDT Readout Mode	MDT Jtag Timestamp
EdgeN1G1300	BA [2018-12-14 10:49:0]
Last Modification Timestamp	BC [2018-12-14 10:49:0]
2018-10-25 12:29:29	EA [2018-12-14 10:48:0]
	EC [2018-12-14 10:48:0]
MDT Extra L1 Latency	0 AMT 0 HPTDC

✓ sMDT subsystem is ready for physics data-taking campaigns!

Stable long DAQ without any mezzanine



# Conclusions



## BIS78 sMDT production and commissioning:

- Successful and on-time production of both A/C-side BIS78 sMDT detectors (~11 000 drift tubes => 16 detectors) from 2017 to 2019.
- 16/16 chambers have been fully assembled and validated at MPI
- In 2019/2020, the 16 A/C-side BIS78 sMDT chambers have been shipped to CERN BB5 facility.
- Each detectors have been fully validated @CERN BB5 facility.
- 8 “A-side” sMDT detectors have been integrated with two new trigger RPC chambers.



## BIS78 Muon module installation and commissioning:

- 8/16 BIS78 Muon station successful installed in ATLAS from Sept. 2020 to Jan. 2021
- 8 sMDT BIS7A have been commissioned!
- 8 sMDT chambers had been integrated into ATLAS DAQ.
- Stable DAQ after long time debug and tests was obtained.
- 1st recorded dataset with all sMDT BIS7A data from ATLAS combined run in M5 has been completed.
- The analysis of data is ongoing!

**We gained valuable experience for the future BIS 1-6 sMDT upgrade project!**





*Thank you to all who helped building, testing, integrating and installing the BIS78 sMDT detectors!*

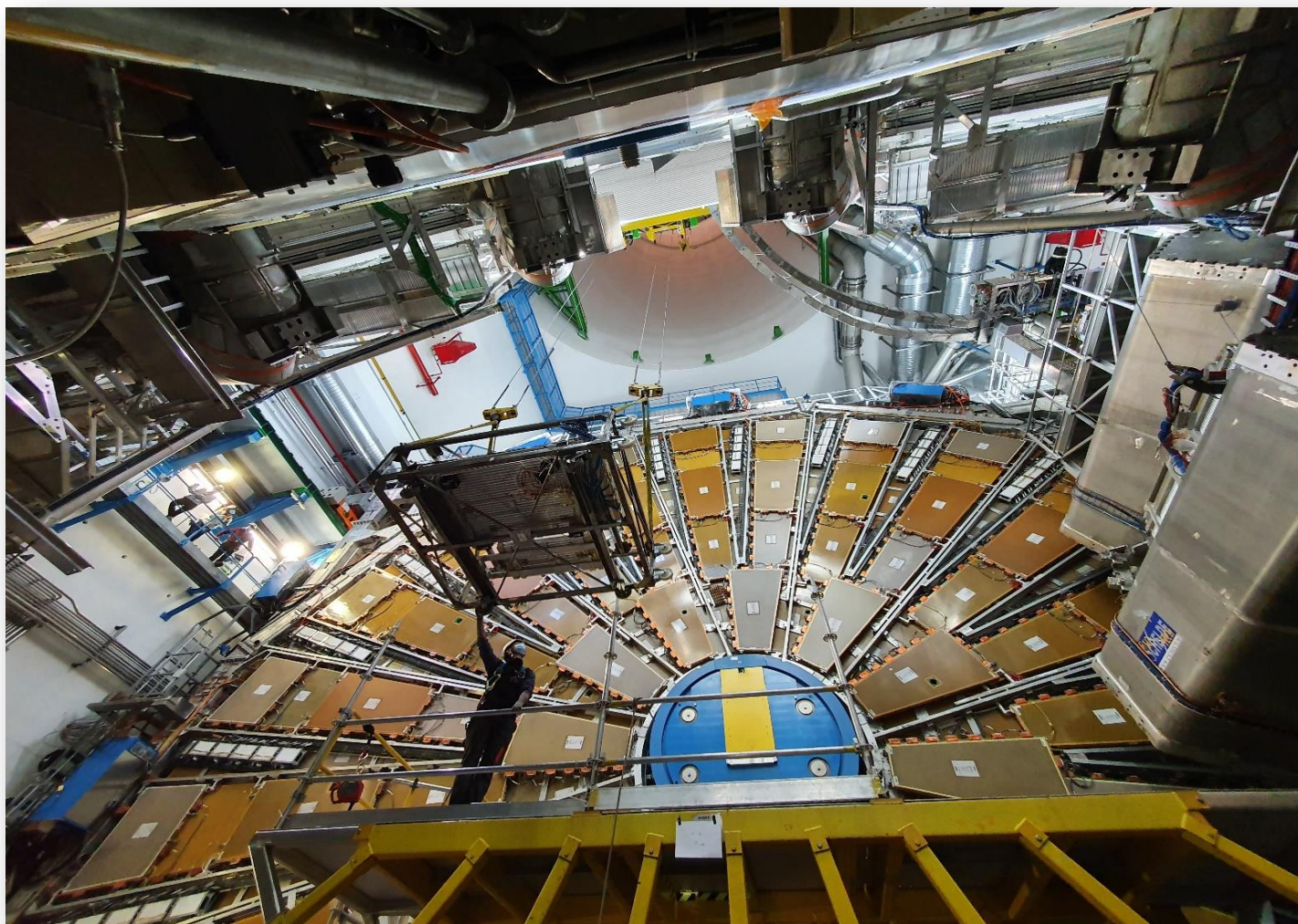

# *Backup slides*



# Current status of the ATLAS Muon Spectrometer

The **ATLAS Muon Spectrometer** was designed to provide muon identification, excellent triggering, timing and momentum measurements at LHC nominal luminosity of  $10 \times 34 \text{ cm}^{-2} \text{ s}^{-1}$ .

*Muon acceptance:  $|\eta| < 2.7$*

Cross section

r - z - plane

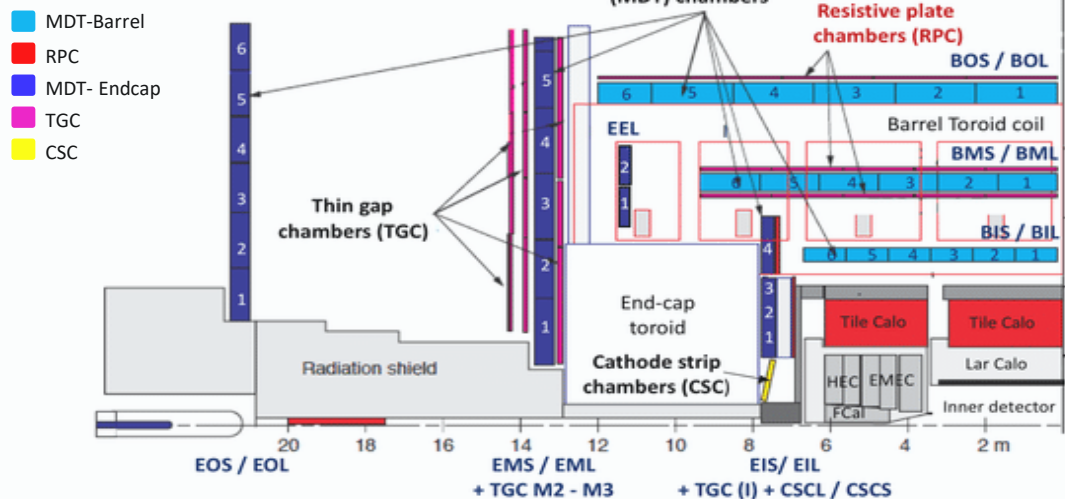

Cross section

r -  $\phi$  - plane

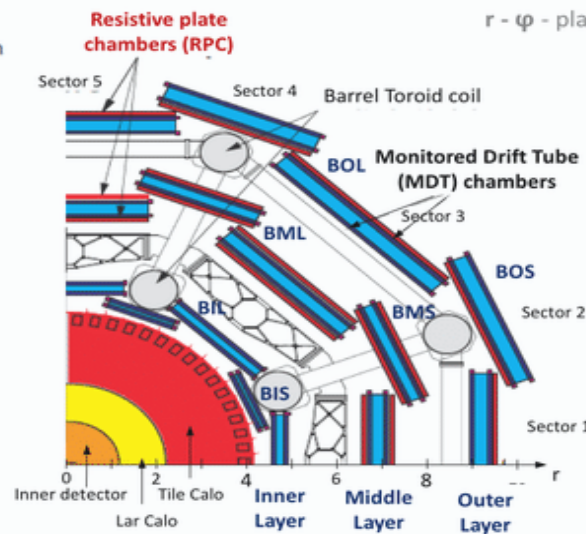

## Four Technologies used for the Muon System:

✓ **Precision Tracking Chambers**

- MDT (Monitored Drift Tubes),  $|\eta| < 2.7$ :
- CSC (Cathode Strip Chambers),  $2.0 < |\eta| < 2.7$ :

✓ **Primary Trigger Chambers**

- RPC (Resistive Plate Chamber),  $|\eta| < 1.05$
- TGC (Thin Gap Chamber),  $1.05 < |\eta| < 2.4$

# Current status of the ATLAS Muon Spectrometer

The **ATLAS Muon Spectrometer** was designed to provide muon identification, excellent triggering, timing and momentum measurements at LHC nominal luminosity of  $10 \times 34 \text{ cm}^{-2} \text{ s}^{-1}$ .

Cross section

r - z - plane

- MDT-Barrel
- RPC
- MDT- Endcap
- TGC
- CSC

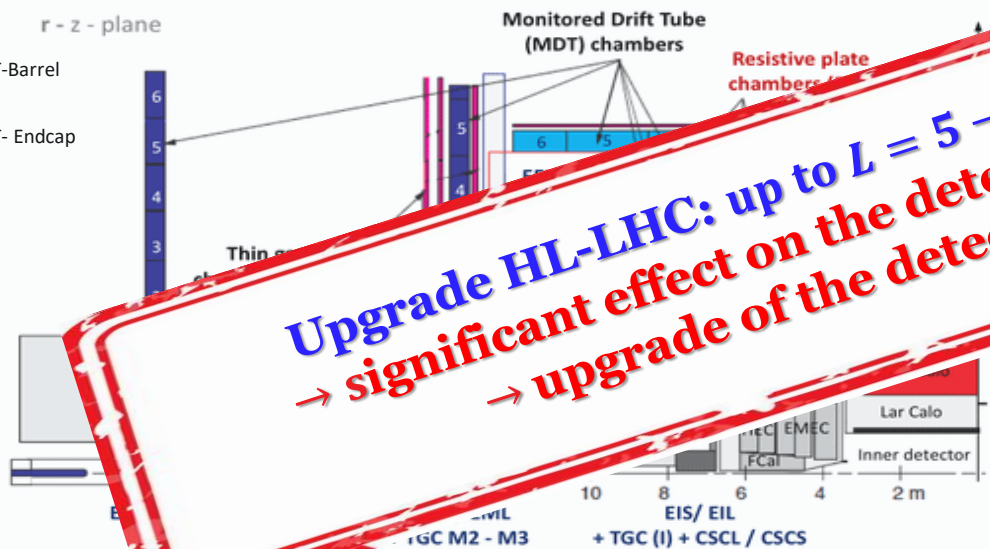

Muon acceptance:  $|\eta| < 2.7$

**Upgrade HL-LHC: up to  $L = 5 - 7 \times 10^{34} \text{ cm}^{-2} \text{ s}^{-1}$**   
 **$\rightarrow$  significant effect on the detection environment**  
 **$\rightarrow$  upgrade of the detectors needed**

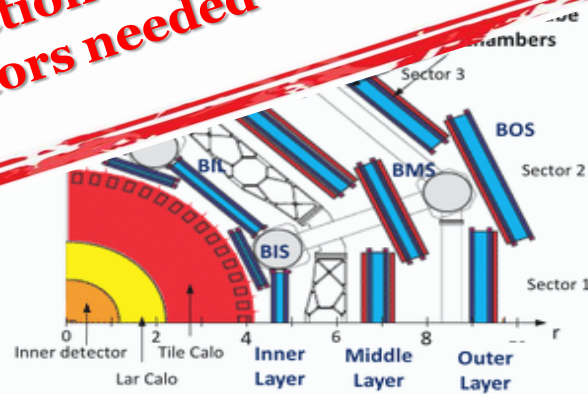

## Four Technologies used for the Muon System:

✓ **Precision Tracking Chambers**

- MDT (Monitored Drift Tubes),  $|\eta| < 2.7$ :
- CSC (Cathode Strip Chambers),  $2.0 < |\eta| < 2.7$ :

✓ **Primary Trigger Chambers**

- RPC (Resistive Plate Chamber),  $|\eta| < 1.05$
- TGC (Thin Gap Chamber),  $1.05 < |\eta| < 2.4$

ATLAS Muon Spectrometer upgrade is motivated by the improving of the high  $p_T$  muon trigger system

## 1. Endcap muon tracking and trigger upgrade at $1.3 < |\eta| < 2.7$ :

The *New Small Wheels* project combine the two different gaseous detector technologies:

- high-resolution **small-strip Thin Gap Chamber (sTGC)** - > **96** detectors for the triggering
- Micro-pattern gaseous detector - **Micromegas (MM)** - > **64** detectors for the tracking

Cross section of a Small Sector

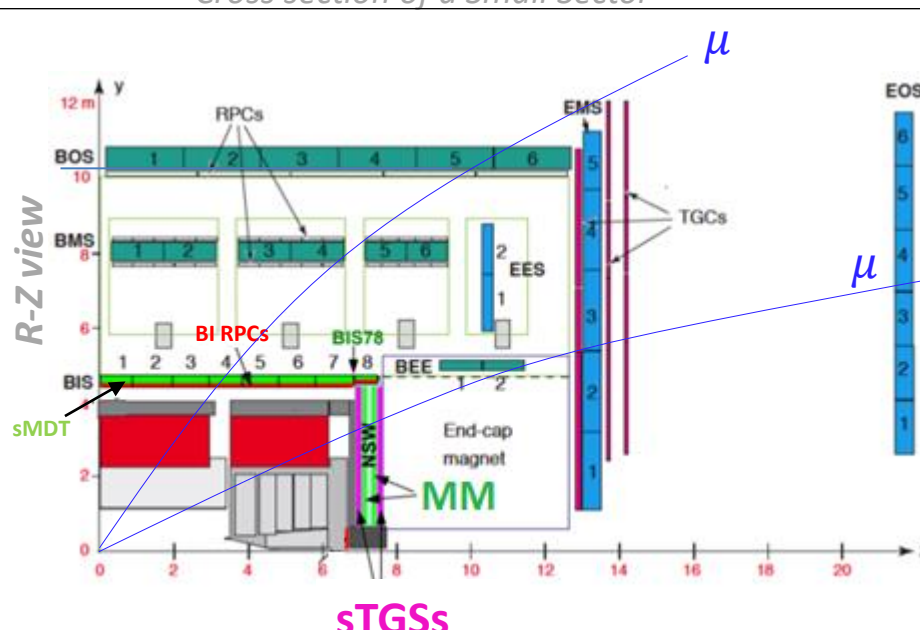

CERN Bldg. 191 - Surface commissioning site of the ATLAS NSW

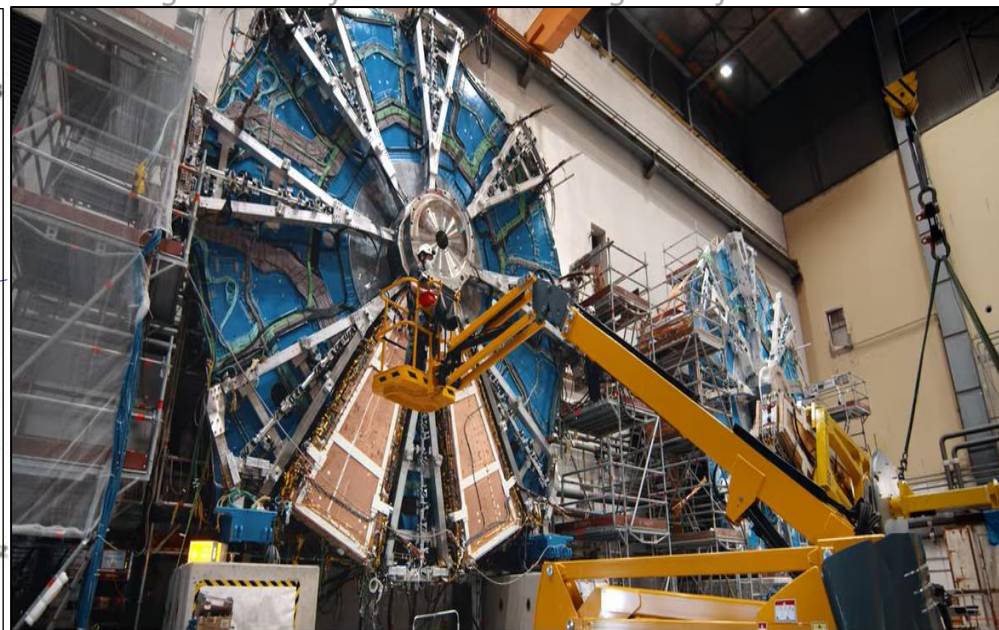



## Preparation of the chamber for the functional test with cosmic muons

1. Evacuate the chamber to  $< 10 \text{ mbar}$  in order to extract the contamination of the chamber gas with ethanol from the leak testing.
2. Fill the chamber with  $\text{Ar:CO}_2$  (93:7) to  $3 \text{ bar}$  absolute pressure.
3. Wait for 30 minutes to get a temperature equilibrium between the chamber and the gas.
4. Measure the chamber temperature and the gas pressure and close all valves on the chamber.  
→ Needed for a measurement of the leak rate of a fully equipped chamber.
5. Apply the nominal operating voltage of  $2730 \text{ V}$  and measure the dark current of the chamber.  
**Requirement:** Current  $< 2 \text{ nA/tube}$  at  $< 60\% \text{ humidity}$ .
6. Measurement of the accidental hit rate in each tube with and without high voltage.
7. Cosmic-ray run to acquire a dataset corresponding to  $\sim 1$  million cosmic muons through the chamber (15 h with the set-up at MPI/BB5, can be shortened by increasing the trigger surface).
8. Measurement of the maximum drift time of each tube to obtain a measure for the uniformity of the space drift-time relationship across the chamber.
9. Measurement of the muon detection efficiency of each tube.
10. Measurement of the single tube resolution.
11. After  $>24 \text{ h}$  measurement of the chamber temperature and the gas pressure for each multilayer separately to obtain the leak rate of each multilayer.

# Gas Leak Rate Test

Identify the **Gas Leak Rate** of the detector by monitoring the drop of the internal pressure as a function of time and check the gas tightness

- The detector is pressurized at **3 bar** in the operating gas mixture **Ar: CO<sub>2</sub> (93:7)**
- The **pressure drop** is measured for each individual multi layers (ML 1 and ML 2 ) after **24 hours** During the test, the gas valves remain closed.
- Instrumentations: pre-mixed gas bottle, MKS Baratron and 12 temperatures sensor glued on the surface of the sMDT detector
- MKS Baratron heated reference differential manometer Accuracy: 0.3 mbar at 3000 mbar
- The detector gas leak are estimated by the following equation:

$$\Delta p = \frac{T_{ref}}{(t_f - t_i)} \times \left( \frac{p_f}{T_f} - \frac{p_i}{T_i} \right) \times \frac{V_{DUT}}{N_{Endplug}}$$

*Reference temperatures (293.15 K)* (pointing to  $T_{ref}$ )  
*Final & Initial pressures* (pointing to  $p_f$  and  $p_i$ )  
*Final & Initial Temperatures* (pointing to  $T_f$  and  $T_i$ )

MKS Instruments  
390HA-00001SP12



- Accuracy of the pressure drop measurement:

$$\delta(\Delta p) \approx \sqrt{2(\delta p)^2 + 2 \left( 3000 \text{ mbar} \frac{\delta T}{T_{ref}} \right)^2} = 1.6 - 2 \text{ mbar}$$

→ **Acceptance criteria**

The detector under test is validated if the pressure drop in the detector + gas system does not exceed:

$$\Delta p \leq 2n_{tubes} \times 10^{-8} \text{ bar} \times \text{Liters} \times s^{-1}$$

# Gas Leak Rate Measurement

## Determination of Gas Leak for each Multilayer (ML)

- Detector is pressurized at **3 bar** in the operating gas mixture **Ar: CO<sub>2</sub> (93: 7)**
- Pressure measurement  **$p(t)$**
- Temperature measurement  **$T(t)$**   
(12 on-chamber sensors)
- Duration: **> 24 hours**
- Gas Leak estimation:

$$\text{Leak Rate} = \left[ p_f \cdot \frac{T_{ref}}{T_f} - p_i \cdot \frac{T_{ref}}{T_i} \right] \cdot \frac{V}{(t_f - t_i) \cdot N_{plugs}}$$

$T_{ref} = 293.15 \text{ K}$  – reference temperature

$p_i, p_t, T_i, T_t$  – initial, final pressures and temperatures

$V, N_{plugs}$  – volume under test and number of the tube end plugs

SMDT A02  
is under Gas Leak Test

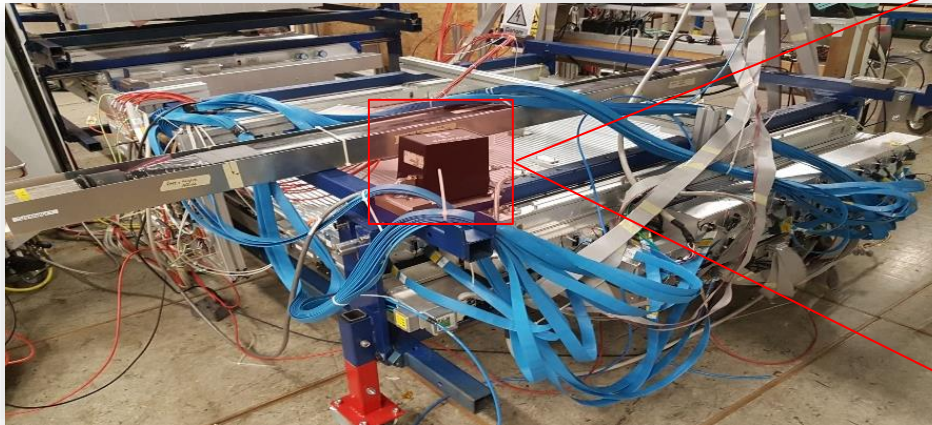

MKS Instruments  
390HA-00001SP12



Accuracy:  
0.3 mbar at 3000 mbar

→ ATLAS acceptance criteria

Detector under test is validated if the pressure drop in the detector + gas system doesn't exceed:

$$\Delta p \leq 2n_{tubes} \times 10^{-8} \text{ bar} \times \text{Liters} \times s^{-1}$$

All data and results obtained at BB5 facility are verified against measurements in MPI.

# Connectivity & Electronics Noise Test

## Determination of Noise Rate for each Chamber Service Module (CSM)

- Detector is pressurized at **3 bar** in the operating gas mixture **Ar: CO<sub>2</sub> (93: 7)**
- Random Trigger
- Measurement Hits/Tube
- Convert to noise rate using active time window of read-out electronics
- Nominal **THR = 108 ASD (-39 mV)**
- Detector configurations: HV turned OFF and ON  
operating  $HV_{WP} = 2730 V$

→ Criteria for excluding noisy tube:

$$Noise_i^{ON} > 5 \text{ kHz} \text{ and } Noise_i^{ON} > 2 \times Noise_i^{OFF}$$

The potential high noise rate sources in the sMDT detectors:

*Discharge of the electr. components*

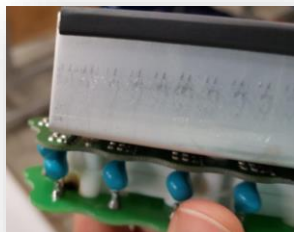

Elena Voevodina

*Broken wire*



DPG-Frühjahrstagungen – Dortmund 2021

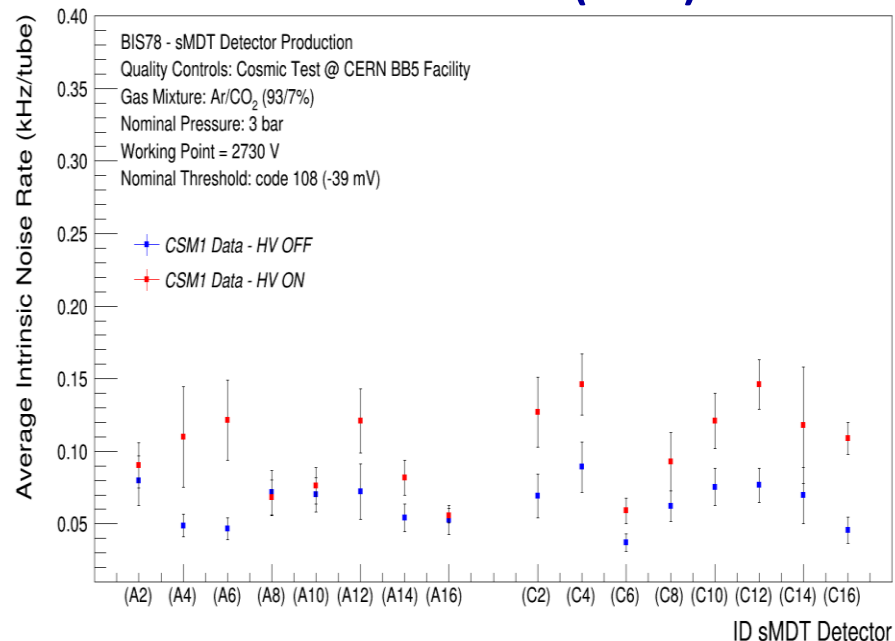

### Noise Rate Test Summary:

→ “A-side” sMDT chamber

Noise Rate (HV OFF) =  $(61.3 \pm 8.3) \text{ Hz/tube}$

Noise Rate (HV ON) =  $(90.6 \pm 9.3) \text{ Hz/tube}$

Rejected tube = 0.1 %

→ “C-side” sMDT chamber

Noise Rate (HV OFF) =  $(65.7 \pm 6.0) \text{ Hz/tube}$

Noise Rate (HV ON) =  $(114.9 \pm 10.1) \text{ Hz/tube}$

Rejected tube = 0.7 %



# Cosmic Ray Test

SMDT setup @CERN BB5: WP = 2730V, P = 3 bar in Ar:CO<sub>2</sub> (93:7)

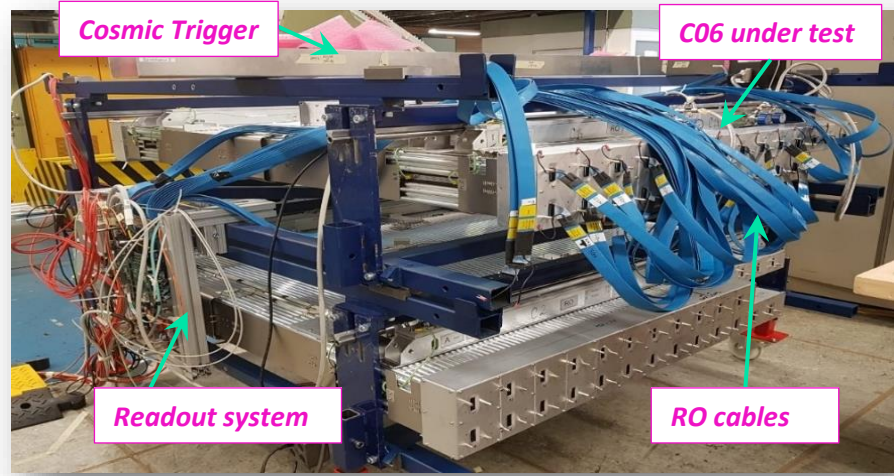

## Maximum drift-time

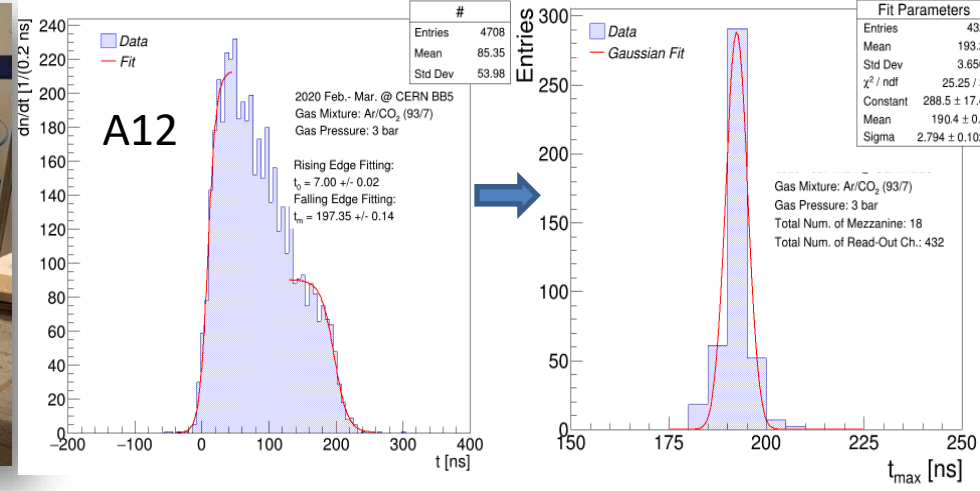

## Spatial Resolution

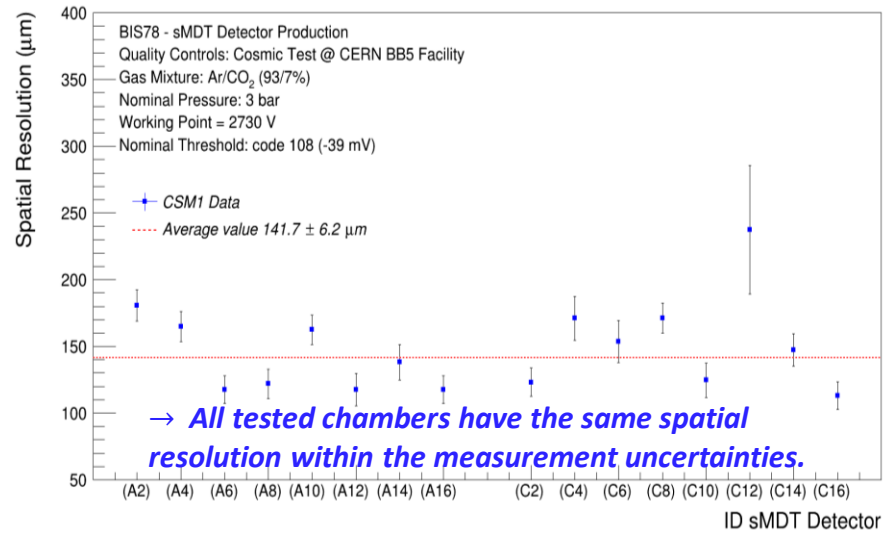

→ The average chamber spacial resolution is 141.7 um which is in agreement with the expectation from the test beam measurement with high energy muons.

## Muon Detection Efficiency

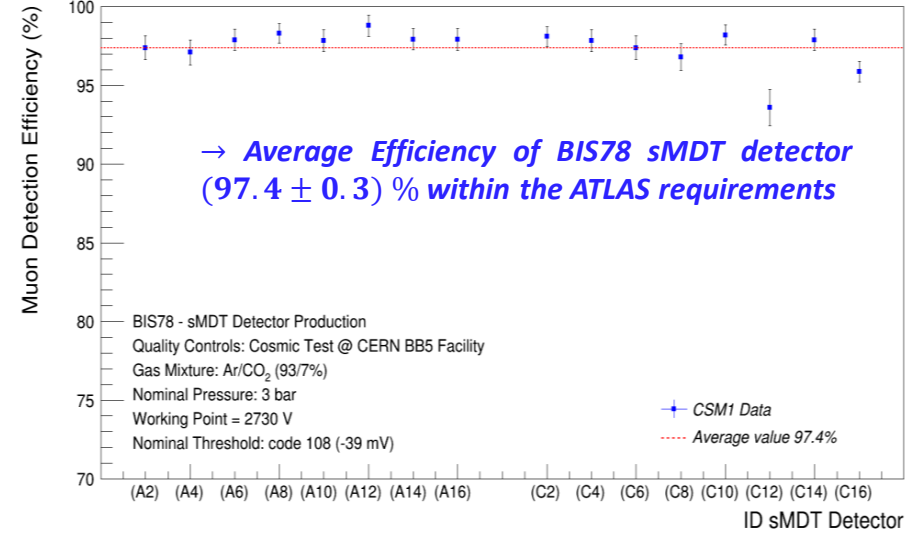

→ The muon efficiency is < 100% because of the efficiency drop close to the tube wall

# Cosmic Ray Test (I)

The last commissioning test is the **Spatial Resolution & Muon Efficiency Measurements** which allows to check that the drift tube is recorded hit, if a reconstructed track is passing through the tube

- The detector is operated at the **WP = 2730 V** and the **3 bar** in gas mixture **Ar:CO<sub>2</sub> (93:7)**
- The duration of the data taking is **15 hrs** per CSM.
- The cosmic trigger active area is **114 cm x 9 cm**.
- Expected trigger rate is **17.1 Hz**.

## Spatial Resolution

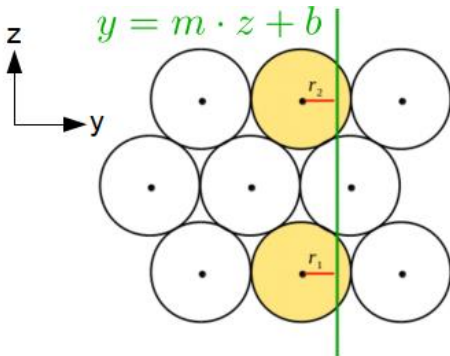

- Select nearly **vertical muon tracks**

→ For perfectly vertical tracks:

$$\sigma(r_1) = 2^{-0.5} \cdot \sigma(r_2 - r_1)$$

- For tracks with inclination  $|m| < 0.01$ :

$$\sigma(r_{1/2}) = \sigma\left(\frac{r_2 - r_1}{\sqrt{2}} \mp \frac{m \cdot (z_2 - z_1)}{\sqrt{2 \cdot (1 + m^2)}}\right)$$

sMDT setup @CERN BB5 facility

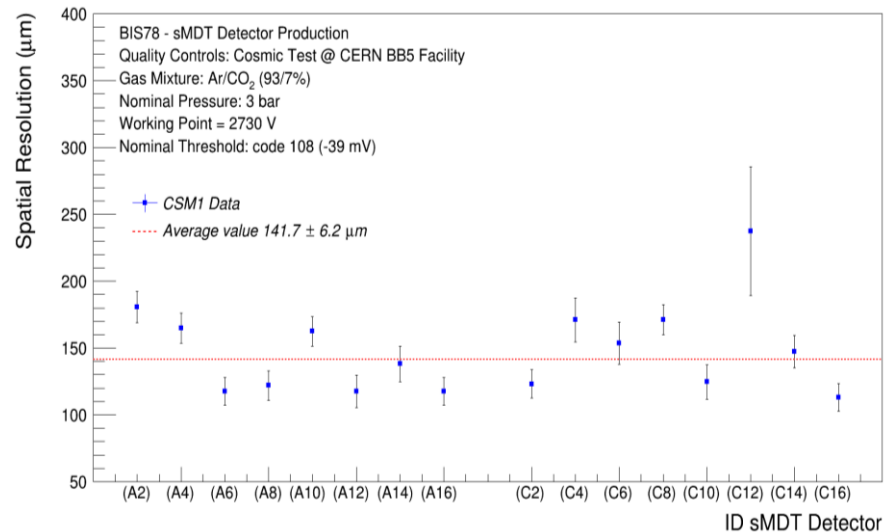
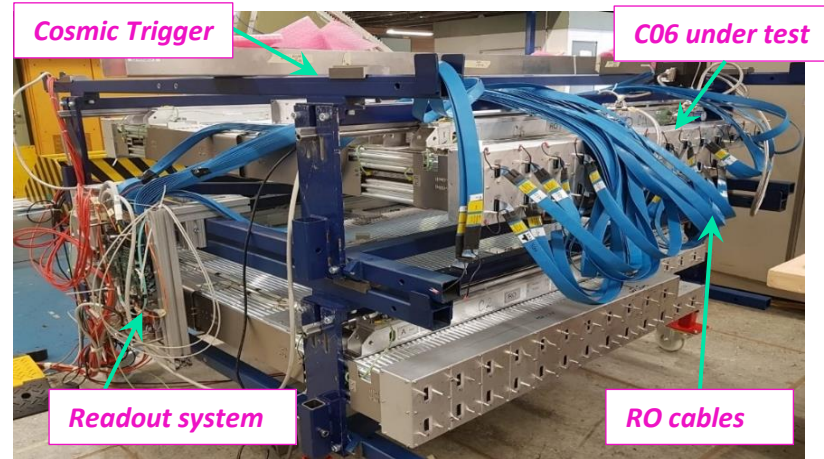

# Cosmic Ray Test (II)

The last commissioning test is the **Spatial Resolution & Muon Efficiency Measurements** which allows to check that the drift tube is recorded hit, if a reconstructed track is passing through the tube

## Muon Detection Efficiency

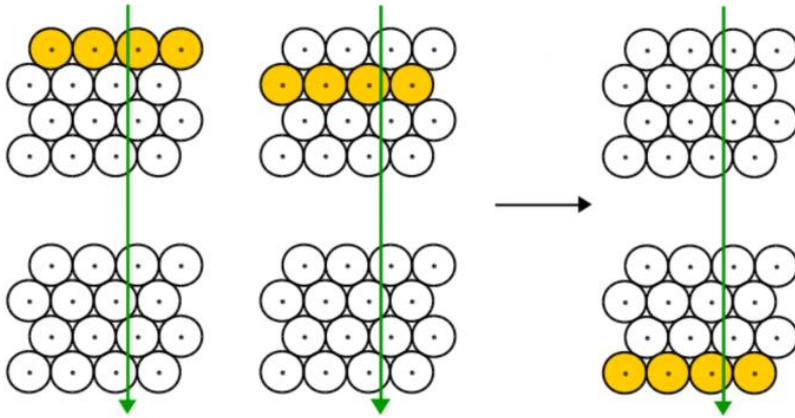

- Measurement reproduces known dependence of the efficiency on the distance of the muon track from anode wire

→ **Average Efficiency of BIS78 sMDT detector ( $97.4 \pm 0.2$ ) % within the ATLAS requirements**

→ **The muon efficiency is < 100% because of the efficiency drop close to the tube walls**

- Muon track is reconstructed by excluding one layer of tubes
- Muon detection efficiency** of a tube is determined as to how often does an excluded tube have a hit when its gas volume is traversed by a reconstructed muon track

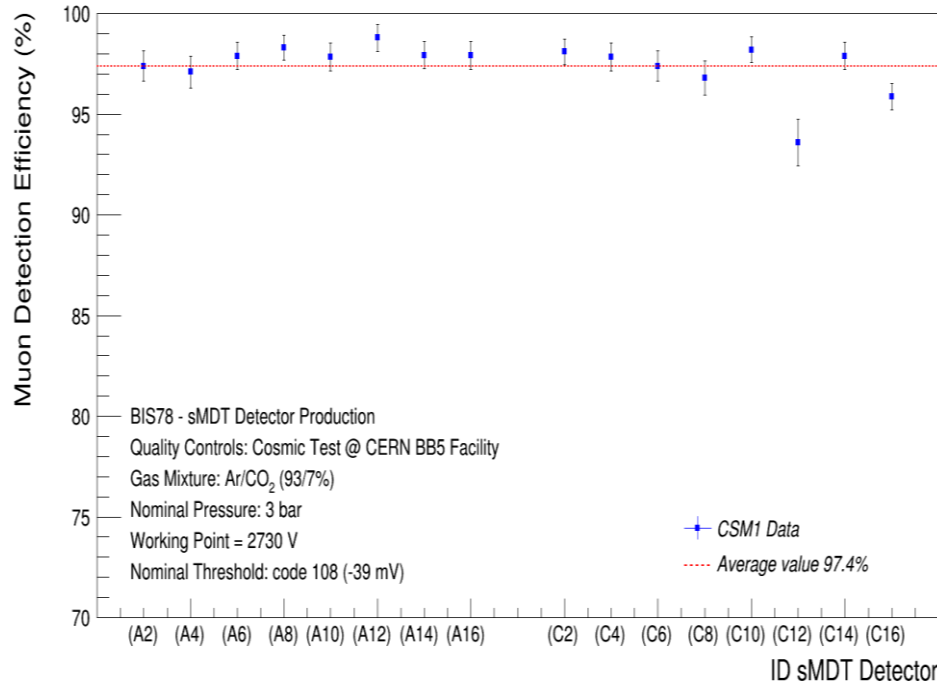



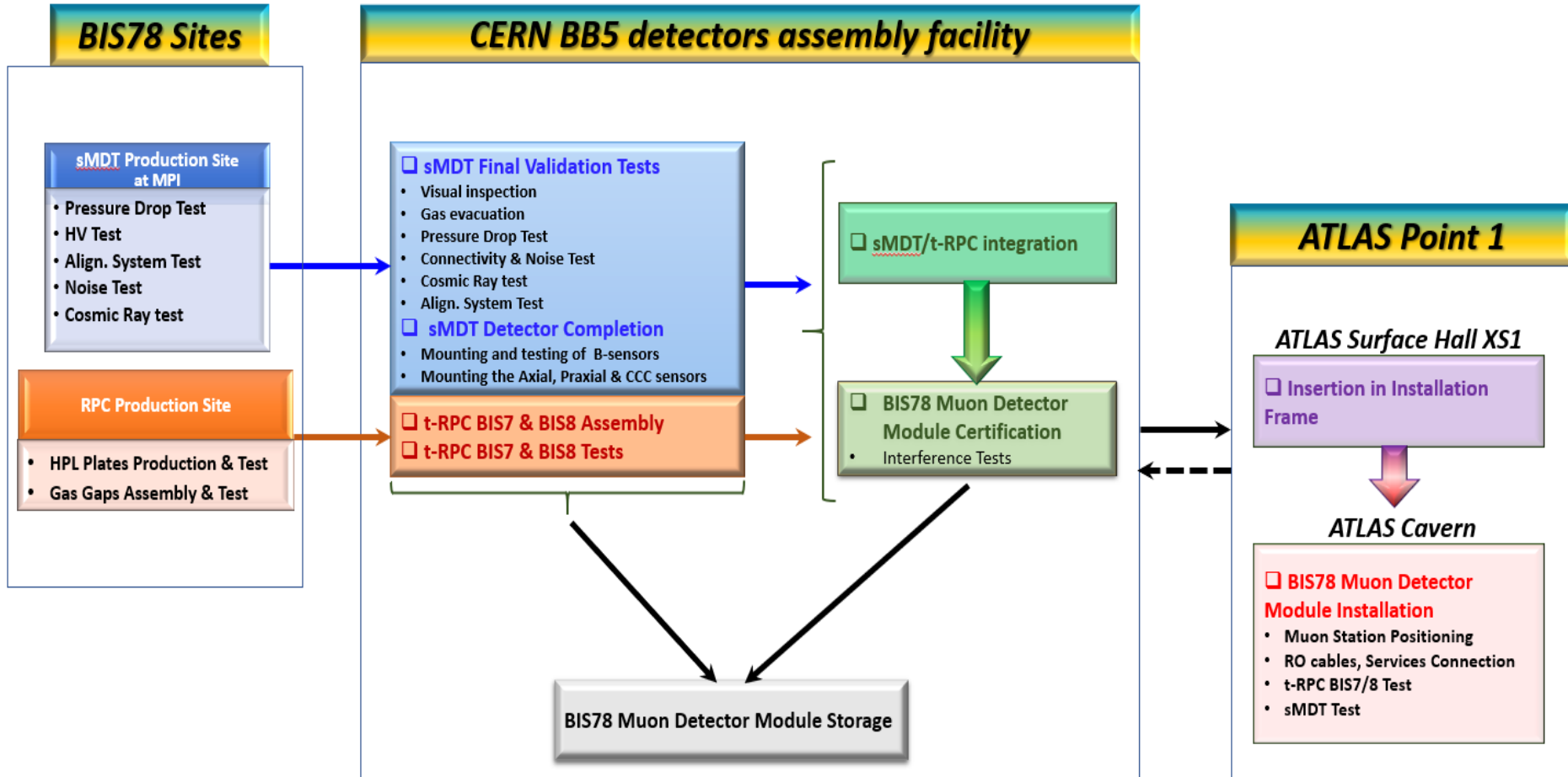

# sMDT "C-side" module status @ BB5

Summary of BIS78 C-side sMDT status and progress @ BB5 facility

	Visual Inspection	Gas Leak Rate Test	Connectivity & Electronic Noise Test	Cosmic Ray Test	Storage Location
C02	Validated	Validated	Validated	Validated	Meyrin bldg. 175
C04	Validated	Validated	Validated	Validated	Meyrin bldg. 175
C06	Validated	Validated	Validated	Validated	BB5 facility
C08	Validated	Validated	Validated	Validated	Meyrin bldg. 175
C10	Validated	Validated	Validated	Validated	Meyrin bldg. 175
C12	Validated	Validated	Validated	Validated	Meyrin bldg. 175
C14	Validated	Validated	Validated	Validated	Meyrin bldg. 175
C16	Validated	Validated	Validated	Validated	Meyrin bldg. 175

*All chambers have been fully validated!*

C-side sMDT Storage @Meyrin bldg. 175



- ✓ 8 "C-side" sMDT BIS78 modules have been delivered from the MPI-Munich at the beginning of June 2020 when the storage and test spaces at CERN were available
- ✓ 8 C-side sMDT chambers have been fully validated @CERN BB5 facility
- ✓ 7 tested detectors have been safety stored @CERN Meyrin site (bldg. 175)
- ✓ 1 (C06) chamber has been stored at the BB5 facility for the mechanics improvement activity
- ✓ All chambers will be re-validated again before the final installation

## Sequence:

- Check connectivity of the electr. components
- Monitor the communication stability
- Noise level measurement
- Identification the noisy/dead channels

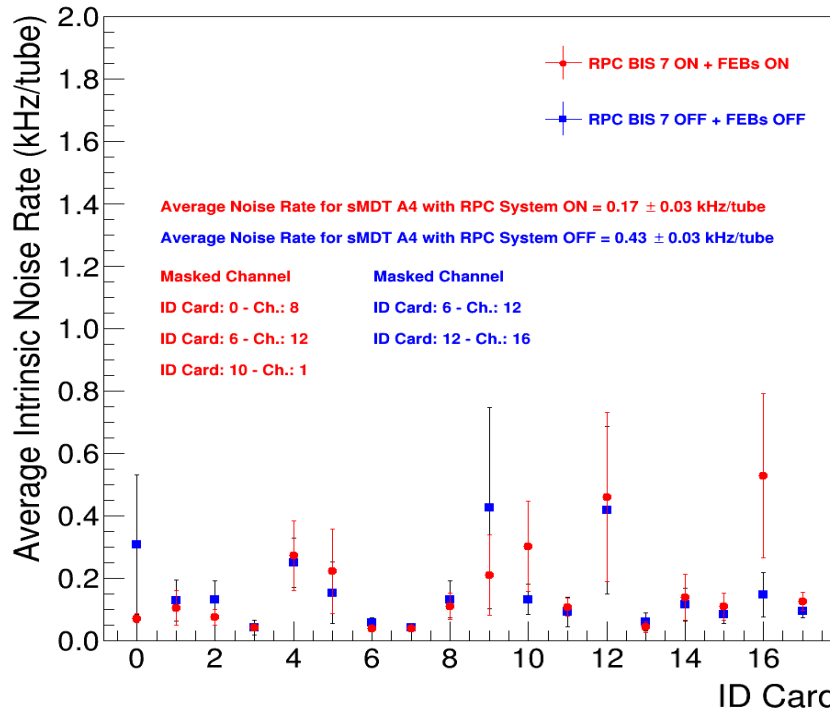

BIS78 A04 - Noise Study @BB5

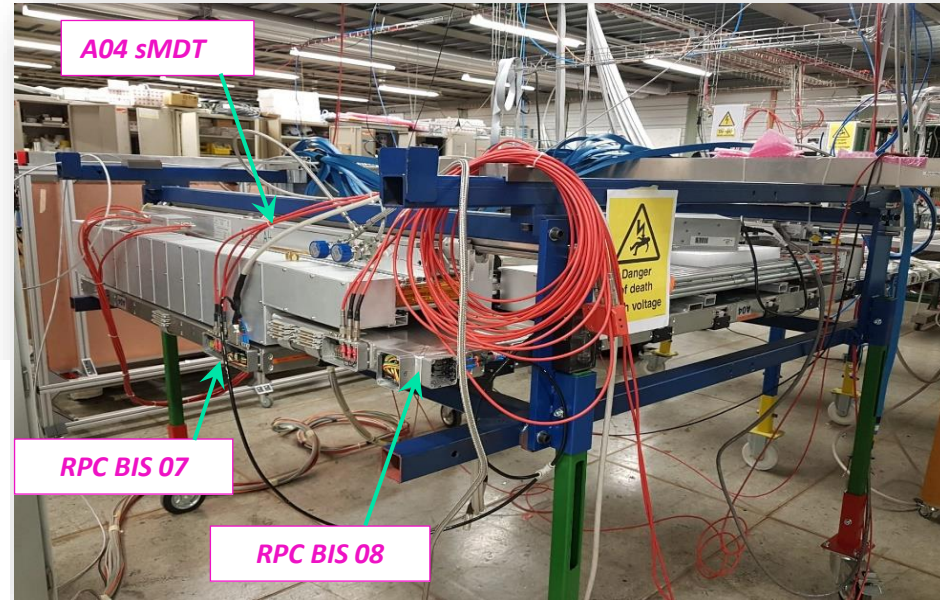

**Detailed study shown that the effect of the RPC detector + its electronics is negligible to sMDT system (chamber + its electronics @ operating THR. = -39 V) in the term of noise!**